

TEKA

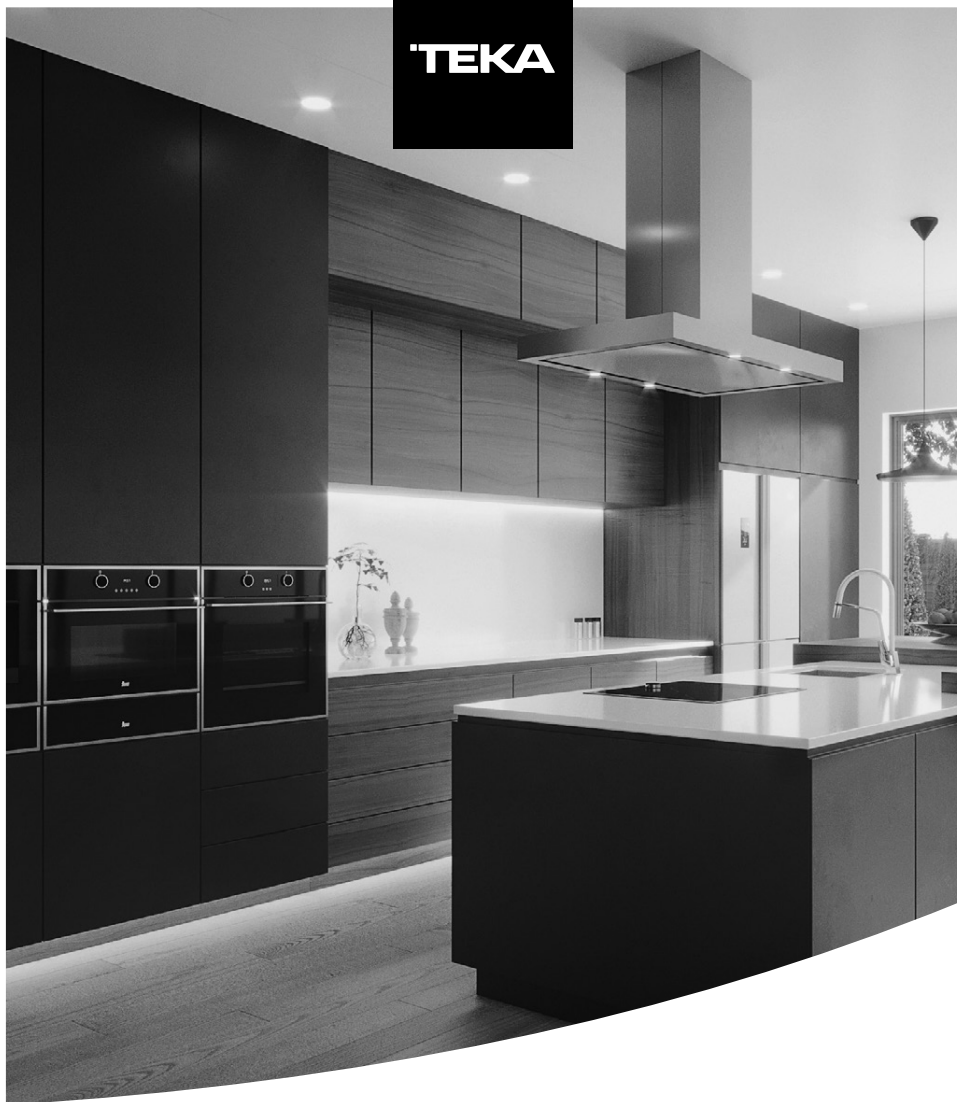

User Manual

MWE FS20 G WH

ES PT EN FR DE **TR**

teka.com

Horno microondas

Manual de instrucciones

Modelo: MWE FS20 G WH

Lea atentamente estas instrucciones antes de utilizar el horno de microondas y guárdelas cuidadosamente.

Si sigue las instrucciones, su horno le proporcionará un buen servicio durante muchos años.

GUARDE ESTAS INSTRUCCIONES

EXPOSICIÓN EXCESIVA A ENERGÍA DE MICROONDAS

- (a) No intente hacer funcionar este horno microondas con la puerta abierta ya que podría suponer una exposición perjudicial a la energía de microondas. Es importante no forzar los cierres de seguridad.
- (b) No coloque ningún objeto entre la parte frontal del horno y la puerta, y evite que se acumule suciedad o restos de detergentes limpiadores en las superficies de sellado.
- (c) **ADVERTENCIA:** Si la puerta o juntas de la puerta están dañadas, el horno no debe utilizarse hasta que haya sido reparado por una persona competente.

ADDENDUM

Si el aparato no se mantiene en un buen estado de limpieza, su superficie se podría degradar y afectar a la vida útil del aparato, dando lugar a una situación peligrosa.

ESPECIFICACIONES

Modelo:	MWE FS20 G WH
Tensión nominal:	230 V~ 50 Hz
Potencia de entrada (microondas):	1050 W
Potencia de salida (microondas):	700 W
Potencia Nominal de Entrada (Parrilla):	1000 W

MEDIDAS DE SEGURIDAD

ADVERTENCIAS

Para reducir el riesgo de quemaduras, electrocución, incendio, lesiones o exposición excesiva a la energía del horno microondas al usar el electrodoméstico, siga las precauciones básicas de seguridad, incluidas las siguientes:

1. Lea y siga las instrucciones específicas:
"PRECAUCIONES PARA EVITAR UNA POSIBLE EXPOSICIÓN EXCESIVA A ENERGÍA DE MICROONDAS".
2. Este aparato no está diseñado para ser utilizado por personas (incluidos niños) con capacidades físicas, sensoriales o mentales reducidas, o con falta de experiencia y conocimiento, a menos que sean supervisados o instruidos acerca del uso del aparato por una persona responsable de su seguridad.
3. Se debe vigilar a los niños para asegurarse de que no jueguen con el aparato.
4. Si el cable de alimentación está dañado, debe ser reemplazado por el fabricante, su servicio técnico o una persona cualificada para evitar peligro. (Para aparato con accesorio tipo Y)
5. **ADVERTENCIA:** Asegúrese de que el aparato esté apagado antes de sustituir la bombilla de luz para evitar la posibilidad de electrocución.
6. **Aviso:** Es peligroso para cualquier persona que no sea una persona competente llevar a cabo cualquier servicio o reparación que consista en la extracción de una cubierta que impida la exposición a la energía de microondas.
7. **Aviso:** Los líquidos u otros alimentos no deben calentarse en recipientes cerrados ya que podrían explotar.

8. Cuando caliente alimentos en recipientes de plástico o de papel, vigile el horno debido a la posibilidad de ignición.
9. Sólo use utensilios adecuados para su uso en hornos microondas.
10. Si emite humo, apague o desenchufe el aparato y mantenga la puerta cerrada para sofocar las llamas.
11. El calentamiento por microondas de bebidas puede resultar en retraso en ebullición eruptiva; por lo tanto se debe tener cuidado al manipular el recipiente.
12. El contenido de los biberones y potitos se debe remover o agitar y revisar la temperatura antes de su consumo, para evitar quemaduras.
13. Los huevos con cáscara y huevos duros enteros no deben ser calentados en hornos microondas ya que podrían explotar, incluso después de que el calentamiento por microondas haya terminado.
14. El horno se debe limpiar con regularidad y los depósitos de alimentos deben ser eliminados.
15. Si no mantiene el horno en condiciones limpias podría dar lugar a un deterioro de la superficie que podría afectar negativamente a la vida del aparato y provocar una situación peligrosa.
16. El aparato no debe instalarse detrás de una puerta decorativa con el fin de evitar sobrecalentamientos. (Esto no se aplica a los aparatos con puerta decorativa).
17. Utilice únicamente la sonda de temperatura recomendada para este horno (hornos con posibilidad de utilizar una sonda de temperatura).
18. El horno de microondas no debe colocarse en un gabinete a menos que haya sido probado en el mismo.
19. El horno de microondas deberá funcionar con la puerta decorativa abierta. (para hornos con puerta decorativa).

20. Este aparato está destinado a ser utilizado en hogares y aplicaciones similares, tales como:
 - relacionadas con el personal de las áreas de cocina en tiendas, oficinas y otros ambientes de trabajo;
 - por clientes en hoteles, moteles y otros entornos de tipo residencial;
 - casas de campo;
 - entornos de tipo alojamiento y desayuno.
21. El horno de microondas está diseñado para calentar alimentos y bebidas. El secado de alimentos o ropa y el calentamiento de almohadillas térmicas, zapatillas, esponjas, paños húmedos y similares pueden provocar riesgo de lesiones, inflamación o incendio.
22. Los recipientes metálicos para alimentos y bebidas no están permitidos durante la cocción con microondas.
23. El aparato no debe limpiarse con un limpiador de vapor.
24. El aparato está diseñado para ser utilizado de forma independiente.
25. La parte trasera del aparato debe colocarse contra la pared.

**LEA ATENTAMENTE Y CONSERVE PARA
FUTURAS CONSULTAS
SÓLO PARA USO DOMÉSTICO.
(NO PARA USO COMERCIAL)**

REDUCIR EL RIESGO DE LESIONES A PERSONAS

INSTRUCCIONES DE CONEXIÓN A TIERRA

PELIGRO

Riesgo de choque eléctrico

Tocar alguno de los componentes internos puede provocar graves lesiones personales o incluso la muerte. No desarme este aparato.

ADVERTENCIA

Riesgo de choque eléctrico

El uso inadecuado de la conexión a tierra puede ocasionar un choque eléctrico. No conecte el dispositivo en un tomacorriente hasta que el primero haya sido correctamente instalado y conectado a tierra.

Este horno debe tener una conexión a tierra. En caso de corto circuito, este tipo de conexión reduce el riesgo de descargas eléctricas al proporcionar un cable de escape para la corriente eléctrica. Este dispositivo está equipado con un cable que cuenta con un enchufe de conexión a tierra. El enchufe debe ser conectado a un tomacorriente correctamente instalado y conectado a tierra.

Consulte con un eléctrico o con personal de servicio técnico calificado si no comprende completamente las instrucciones de conexión a tierra o si tiene dudas sobre si el microondas está conectado a tierra de forma adecuada. Si es necesario utilizar una extensión, sólo utilice una que cuente con 3 cables.

1. Este dispositivo cuenta con un cable de alimentación corto para evitar riesgos relacionados con personas que se puedan enredar o tropezar con un cable largo.
2. Puede utilizar cables más largos o extensiones si tiene cuidado a la hora de manejarlos.

3. Si utiliza cables o extensiones más largos:
 - 1) La clasificación eléctrica marcada del cable o extensión debe ser tan alta como la del propio dispositivo.
 - 2) La extensión debe tener un cable de conexión a tierra tipo 3.
 - 3) El cable más largo debe ser ordenado de tal manera que no represente un peligro para los niños y para evitar que estos últimos lo tiren o se tropiecen de forma involuntaria.

LIMPIEZA

Asegúrese de desenchufar el aparato de la red eléctrica.

1. Limpie la cavidad del horno después de usar con un paño ligeramente húmedo.
2. Limpie los accesorios de la manera habitual con agua y jabón.
3. El marco de la puerta y el sello y partes vecinas deben limpiarse cuidadosamente con un paño húmedo cuando estén sucias.
4. No use limpiadores abrasivos ni rascadores metálicos afilados para limpiar el cristal de la puerta del horno, ya que pueden rayar la superficie, lo que puede provocar la rotura del vidrio.
5. Sugerencia de limpieza --- Para facilitar la limpieza de las paredes internas que la comida cocinada puede tocar: coloque la mitad de un limón en un bol, añada 300 ml (1/2 pinta) de agua y caliente al 100 % de potencia en el microondas durante 10 minutos. Limpie el horno con un paño suave y seco.

UTENSILIOS

PRECAUCIÓN

Peligro de lesiones personales

Los utensilios herméticamente cerrados podrían estallar. Los contenedores cerrados deben ser abiertos y las bolsas de plástico deben ser agujereadas antes de cocinar.

Consulte las instrucciones en "Materiales que puede utilizar en el horno microondas o para evitar en el horno de microondas ".Podrían existir ciertos utensilios no metálicos que podrían no ser seguros de usar en un horno de microondas. Si tiene dudas, puede revisar los utensilios en cuestión siguiendo el procedimiento que le presentamos a continuación:

Revisión de utensilios:

- 1.Llene un contenedor microondeable con una taza de agua (250ml) fría junto con el utensilio que desee probar.
- 2.Cocine a máxima potencia durante un minuto.
- 3.Con cuidado toque el utensilio. Si el utensilio está caliente, entonces no lo utilice en el microondas.
- 4.No exceda el tiempo de 1 minuto.

Materiales que se pueden utilizar en el horno de microondas

Utensilios	Observaciones
Plato para dorar	Siga las recomendaciones del fabricante. El fondo del plato para dorar debe estar al menos 3/16 pulgadas (5mm) por sobre del plato giratorio. Su uso incorrecto podría provocar que el plato se quiebre.
Vajilla	Utilice sólo vajilla microondeable. Siga las recomendaciones del fabricante. No use platos agrietados o astillados.
Recipiente de vidrio	Siempre retire la tapa. Sólo utilícelos para calentar comida. La mayoría de los recipientes de vidrio no son resistentes al calor y podrían quebrarse.
Cristalería	Utilice sólo cristalería resistente al calor. Asegúrese de que no tengan bordes metálicos. No use platos agrietados o astillados.
Bolsas para hornear	Siga las recomendaciones del fabricante. No cierre las bolsas usando ataduras de metal. Realice agujeros para permitir que escape el vapor.
Platos y vasos de papel	Sólo utilícelos para periodos de cocción cortos. No deje el horno sin vigilancia cuando cocine con estos utensilios.
Toallas de papel	Utilícelas para cubrir la comida cuando la recaliente y para absorber la grasa. Utilícelas bajo supervisión y durante periodos de cocción breves.
Papel manteca	Utilícelo como cubierta para evitar salpicones o como envoltura para el vapor.
Plástico	recomendaciones del fabricante. Debe tener una marca que señale que el producto es "Microondeable". Algunos contenedores de plástico se ablandan, pues la comida en su interior se calienta. Las "bolsas de cocción" y las bolsas de plásticos selladas deben ser agujereadas tal y como señalan sus instrucciones.
Envoltura plástica	Utilice sólo productos microondeables. Utilícelo para cubrir la comida y retener la humedad. No permita que las envolturas de plástico toquen la comida.
Termómetros	Utilice sólo utensilios microondeables (termómetros de carne y dulce).
Papel encerado	Utilícelo como cubierta para evitar salpicaduras y retener humedad.

Materiales que deben evitarse en el horno de microondas

Utensilios	Observaciones
Bandeja de aluminio	Podría provocar un arco eléctrico. Transfiera la comida a un plato microondeable.
Comida envuelta con manijas de metal	Podría provocar un arco eléctrico. Transfiera la comida a un plato microondeable.
Utensilios de metal o con decoraciones metálicas	El metal blindará la comida de la energía de microondas. Las decoraciones de metal podrían producir arcos eléctricos.
Ataduras de metal	Podrían causar arcos eléctricos y provocar incendios en el horno.
Bolsas de papel	Podrían provocar incendio en el horno.
Porexpan	El porexpán podría derretirse y contaminar la comida cuando se expone a altas temperaturas.
Madera	La madera podría secarse cuando la utilice en el horno de microondas y podría partirse o agrietarse.

NOMBRES DE LAS PARTES DEL HORNO Y ACCESORIOS

(En caso de cualquier diferencia entre el aparato y las imágenes de este manual, prevalecerá el producto.)

Retire el horno y todos los materiales de la caja de cartón y de la cavidad del horno. Su horno posee los siguientes accesorios:

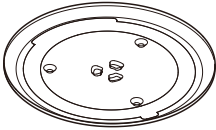

Bandeja de vidrio



Ensamble de anillo de bandeja giratoria



Manual de instrucciones



Eje giratorio

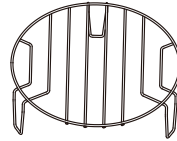

Rejilla (No se puede usar en la función de microondas y debe colocarse en la bandeja de vidrio)

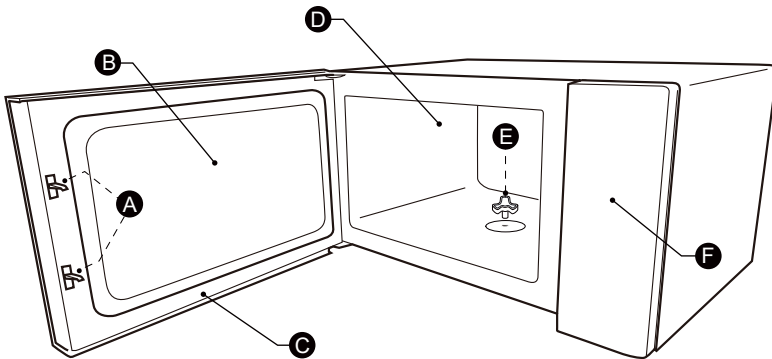

A) Sistema de bloqueo de seguridad
B) Ventana de observación
C) Montaje de la puerta

D) Cavidad del horno
E) Eje giratorio
F) Panel de control

INSTALACIÓN DEL PLATO GIRATORIO

Limpie el compartimento de cocción y coloque el plato giratorio.

Para instalaciones nuevas, asegúrese de haber retirado todo el embalaje y la cinta de envío del eje del plato giratorio. Antes de utilizar el aparato para preparar alimentos por primera vez, deberá colocar correctamente el plato giratorio. Debe limpiar el compartimento de cocción y los accesorios.

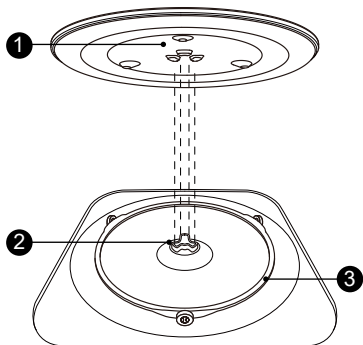

Cómo colocar el plato giratorio en su lugar:

1. Coloque el conjunto del anillo de bandeja giratoria (3) en el hueco del compartimento de cocción.
2. Coloque la bandeja de vidrio (1) en el conjunto del anillo de bandeja giratoria (3). Coloque las líneas curvas elevadas en el centro del fondo de la bandeja de vidrio entre los tres radios del eje. Asegúrese de que la bandeja de vidrio (1) encaje en el eje giratorio (2) en el centro de la base del compartimento de cocción. Los rodillos del eje deben encajar dentro del borde inferior del plato giratorio.

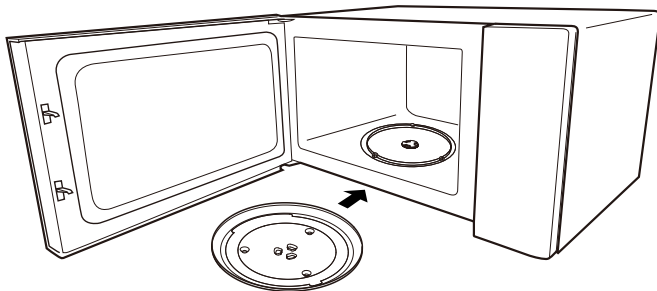

Notas:

1. Nunca utilice el aparato sin el plato giratorio. Asegúrate de que esté correctamente enganchado. El plato giratorio puede girar en sentido horario o antihorario.
2. Nunca coloque la bandeja de vidrio al revés. La bandeja de vidrio nunca debe tener restricciones que la imposibiliten de girar.
3. Tanto la bandeja de vidrio como el ensamblaje del anillo de la misma deben usarse a la hora de cocinar.
4. Toda la comida y los contenedores de comida deben colocarse sobre la bandeja de vidrio para cocinar o calentar.
5. Nunca restrinja el movimiento del plato giratorio.
6. Si la bandeja de vidrio o el ensamblaje del anillo de la misma se triza o rompe, contacte al centro de servicio técnico autorizado más cercano.

Instalación de encimeras

Retire todo el material de embalaje y los accesorios. Revise el horno en busca de daños, como abolladuras o la puerta rota. No instale el horno si presenta daños.

Gabinete: Retire cualquier película protectora que se encuentre en la superficie del gabinete del horno de microondas. No retire la cubierta de la guía de ondas que está fijada a la cavidad del horno para proteger el magnetrón.

Instalación

1. Seleccione una superficie nivelada que proporcione espacio suficiente para las ranuras de ventilación de entrada y salida del aparato.

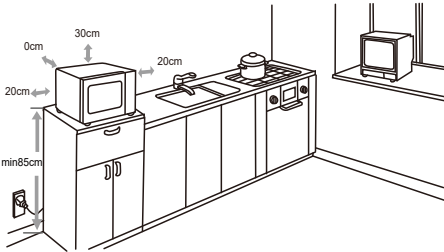

(1) La altura mínima de instalación es de 85 cm.

(2) La parte trasera del aparato debe colocarse contra una pared. Deje un espacio libre mínimo de 30 cm por encima del horno, se requiere un espacio libre mínimo de 20 cm entre el horno y cualquier pared adyacente.

(3) No retire las patas de la parte inferior del horno.

(4) El bloqueo de las aberturas de entrada y/o salida puede dañar el horno.

(5) Coloque el horno lo más lejos posible de radios y TV. El funcionamiento del horno microondas puede causar interferencias en la recepción de su radio o TV.

2. Conecte su horno en un tomacorriente casero estándar. Asegúrese de que el voltaje y la frecuencia sean las mismas que aparecen en la etiqueta de clasificación del horno.

ADVERTENCIA

No coloque el horno sobre una estufa o parrillas u otros aparatos productores de calor. Si instala el horno cerca o sobre una fuente de calor, podría dañarlo y la garantía quedaría inválida.

Las superficies accesibles pueden calentarse durante el funcionamiento.



Panel de control

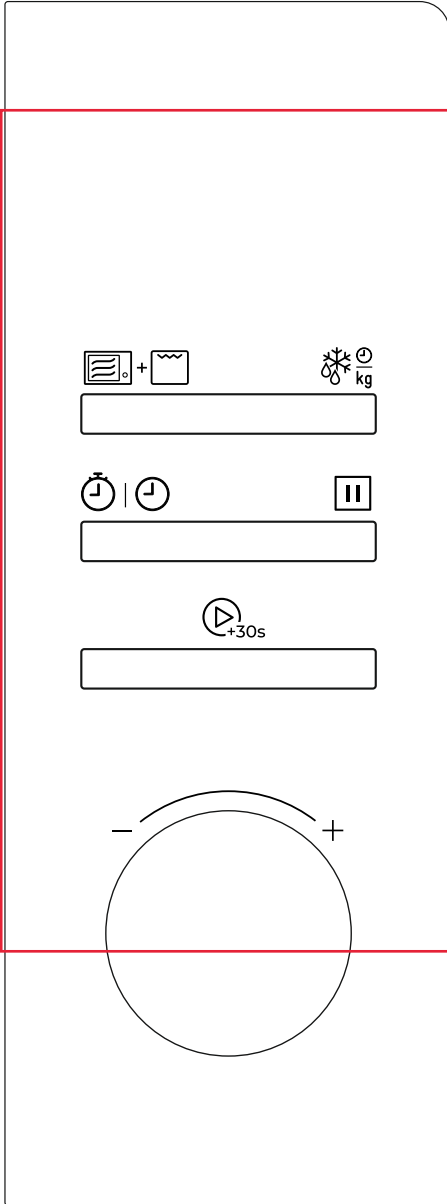

 Función (Microondas+Parrilla+Combi)

 Descongelar por Peso/Descongelar por Tiempo







 Temporizador/Reloj

 Detener/Cancelar



 Iniciar/+30 Seg./Cocción Rápida

FUNCIONAMIENTO



1. Ajuste del reloj

- (1) Presione "  |  " dos veces y "00:00" aparecerá en pantalla.
- (2) Gire la perilla para ajustar las cifras de la hora.
- (3) Presione "  |  " para confirmar.
- (4) Gire la perilla para ajustar las cifras de los minutos.
- (5) Presione "  |  " para confirmar. El reloj habrá sido ajustado.

Notas:

- (1) El reloj posee una visualización de 24 horas. Si el reloj no se configura, no funcionará cuando esté encendido.
- (2) Para restablecer el reloj, repita desde el paso 1 al paso 5.
- (3) Después de configurar el reloj, si no se presiona "  |  " o no hay operación dentro de 1 minuto, la configuración será inválida.

2. Ajuste del temporizador







- (1) Presione "  |  " una vez y "0:00" aparecerá en pantalla.
- (2) Gire la perilla para configurar el tiempo deseado. El tiempo máximo corresponde a "95:00".
- (3) Presione "  " para confirmar. El temporizador iniciará la cuenta atrás.

Nota: Esta función corresponde a un temporizador de cocina.



3. Cocción por microondas

Tabla de Potencia del Microondas

Potencia de microondas	100%	80%	50%	30%	10%
Visualización	P100	P80	P50	P30	P10

- (1) Presione "  +  " una vez y "P100" aparecerá en pantalla.
- (2) Presione "  +  " repetidamente para ajustar el nivel de potencia. Eiveles de sisten 5 n potencia disponibles.
- (3) Presione "  " para confirmar.
- (4) Gire la perilla para configurar el tiempo de cocción. El tiempo máximo corresponde a "95:00".
- (5) Presione "  " para iniciar la cocción.

4. Descongelar por peso



(1) Pulse "  *  " una vez, la pantalla mostrará "dEF1".

(2) Gire la perilla para configurar el peso de los alimentos. El rango de peso es de 100-2000g.

(3) Presione "  +30s " para iniciar el descongelamiento.

Nota: Durante el descongelamiento, el zumbador emitirá un pitido para recordarle que debe voltear los alimentos. Si no hay ninguna operación, el horno seguirá funcionando.

5. Descongelar por tiempo

(1) Presione "  *  " dos veces, la pantalla mostrará "dEF2".

(2) Gire la perilla para configurar el tiempo de descongelamiento deseado. El tiempo máximo corresponde a "95:00".

(3) Presione "  +30s " para iniciar el descongelamiento.

Notas:

(1) Durante el descongelamiento, el zumbador emitirá un pitido para recordarle que debe voltear los alimentos. Si no hay ninguna operación, el horno seguirá funcionando.

(2) El nivel de potencia descongelamiento es de P30 y no puede ser cambiado.

6. Cocción rápida

(1) En modalidad de espera, presione "  +30s " para cocinar los alimentos a un nivel de potencia de 100% durante 30 segundos. Cada pulsación del mismo botón puede aumentar 30 segundos y el valor máximo de tiempo es "95:00".

(2) En modo de espera, gire la perilla a la izquierda para configurar un tiempo de cocción al 100% de potencia. Continúe girando la perilla para ajustar el tiempo de cocción. El valor máximo del tiempo es "95:00". Luego presione "  +30s " para comenzar a cocinar.







Nota: En la modalidad de cocción y descongelamiento por tiempo, cada vez que presione "  +30s " puede aumentar el tiempo de cocción en 30 segundos (excepto para el descongelamiento por peso, el menú automático y la primera etapa de cocción en múltiples etapas)

7. Cocción multietapag







Notas: (1) En la cocción multietapa se pueden ajustar dos etapas de cocción.

- (2) Si ajusta la función de descongelamiento, esta se convertirá en la primera etapa automáticamente.
- (3) El temporizador de cocina y el menú automático no pueden configurarse como una de las etapas múltiples.

Ejemplo: Descongele los alimentos durante 5 minutos y, a continuación, cocínelos a una potencia de microondas de 80% durante 7 minutos.

- (1) Presione "  kg " dos veces y "dEF2" aparecerá en pantalla.
- (2) Gire la perilla para configurar el tiempo de descongelación deseado a 5 minutos.
- (3) Presione "  +  " una vez y "P100" aparecerá en pantalla.
- (4) Presione "  +  " nuevamente o gire la perilla para configurar el nivel de potencia a P80.
- (5) Presione "  " para confirmar.
- (6) Gire la perilla para configurar el tiempo de cocción a 7 minutos.
- (7) Presione "  " para iniciar la cocción.

8. Cocción a la parrilla y cocción combinada

- (1) Presione "  +  " una vez y "P100" aparecerá en pantalla.
- (2) Presione "  +  " repetidamente o gire la perilla hasta que se muestren "G-1", "C-1" y "C-2" en orden..
- (3) Presione "  " para confirmar.
- (4) Gire la perilla para configurar el tiempo de cocción. El tiempo máximo corresponde a "95:00".
- (5) Presione "  " para iniciar la cocción.

Nota: El zumbador sonará para recordarle que debe dar vuelta a los alimentos durante la cocción a la parrilla. Si no hay ninguna operación, el horno seguirá funcionando.

Tabla de Cocción Combinada

Función	Visualización	Potencia de microondas	Potencia de la parrilla
Combi. 1	C-1	55%	45%
Combi. 2	C-2	36%	64%

9. Menú automático



- (1) Gire la perilla a la derecha y luego se mostrará "A-1".
- (2) Continúe girando la perilla para elegir el menú que necesita. Hay 8 menús automáticos disponibles.
- (3) Presione "  " para confirmar.
- (4) Gire la perilla para configurar el peso de los alimentos.
- (5) Presione "  " para iniciar la cocción.



Tabla de menú automático

Menú	Peso	Visualización	Potencia
A-1 Recalentamiento o automático	200g	200	P100
	400g	400	
	600g	600	
A-2 Verduras	300g	300	P100
	400g	400	
A-3 Pescado	250g	250	P80
	350g	350	
	450g	450	
A-4 Carne	250g	250	P100
	350g	350	
	450g	450	
A-5 Pasta	50g(con 450g de agua fría)	50	P80
	100g(con 800g de agua fría)	100	
A-6 Patata	200g	200	P100
	400g	400	
	600g	600	
A-7 Pizza	200g	200	P100
	400g	400	
A-8 Sopa	200ml	200	P100
	400ml	400	

10. Función de bloqueo para niños

Puede utilizar esta función para evitar que los niños enciendan accidentalmente el horno.



Para activar la función de bloqueo:



En modalidad de espera, presione y mantenga presionado "  " durante 3 segundos. Sonará un pitido largo y se mostrará "  ".

Para desactivar la función de bloqueo:

En estado de bloqueo, presione y mantenga presionado "  " durante tres segundos. Sonará un pitido largo.

11. Función de consultas

(1) Si el reloj ha sido ajustado, la hora actual se mostrará durante tres segundos pulsando "  |  " en la modalidad de cocción.

(2) En el estado de cocción de microondas, parrilla y combinación, presione "  +  " para consultar el nivel de potencia o el modo de cocción. La potencia se visualizará durante 3 segundos.

Solución de problemas

Normal	
El horno de microondas provoca interferencia con la recepción de la TV	La recepción de radio y televisión podría ser interferida por el funcionamiento del horno microondas. Esta interferencia es similar a aquella que producen pequeños electrodomésticos como batidoras, aspiradoras y ventiladores eléctricos. Esto es normal.
Luz del horno con baja intensidad	Cuando cocine con baja potencia la luz del horno podría perder intensidad. Esto es normal.
Se acumula vapor en la puerta y sale aire caliente por las ranuras de ventilación.	Cuando cocine la comida puede emitir vapor. La mayoría saldrá por las ranuras de ventilación. Pero se podría acumular en un lugar frío como la puerta del horno. Esto es normal.
El horno se inicia accidentalmente sin comida en el interior.	Está prohibido hacer funcionar esta unidad sin comida en su interior. Esto es peligroso.

Problema	Posible causa	Solución
El horno no puede iniciarse	(1) El cable de alimentación no está bien conectado.	Desconecte el cable. Reconéctelo después de 10 segundos.
	(2) Falla de los fusibles o del sistema del cortacircuitos.	Reemplace el fusible o haga que un profesional repare el cortacircuitos.
	(3) Problema con el tomacorriente.	Verifique el normal funcionamiento del tomacorriente con otros electrodomésticos.
El horno no calienta	(4) La puerta no cerró bien.	Cierre bien la puerta del horno.



De acuerdo con la Directiva de Residuos de Aparatos Eléctricos y Electrónicos (WEEE, por sus siglas en inglés), estos deben recolectarse y tratarse por separado. Si en el futuro, necesita desechar este producto, por favor NO se deshaga de él junto con los residuos del hogar, envíelo a alguno de los puntos de recolección dispuestos por la WEEE donde se encuentren disponibles.

Forno micro-ondas

MANUAL DE INSTRUÇÕES

Modelo: MWE FS20 G WH

Leia atentamente estas instruções antes de usar o forno micro-ondas e guarde-as num local seguro.

Se seguir as instruções, o seu forno irá fornecer-lhe muitos anos de bons serviços.

GUARDE ESTAS INSTRUÇÕES NUM LOCAL SEGURO

PRECAUÇÕES PARA EVITAR POSSÍVEL EXPOSIÇÃO À ENERGIA DE MICRO-ONDAS EXCESSIVA

- (a) Não tente utilizar este forno com a porta aberta, pois isso pode resultar em exposição prejudicial à saúde à energia de micro-ondas. É importante não quebrar ou adulterar os bloqueios de segurança.
- (b) Não coloque nenhum objeto entre a face frontal do forno e a porta, nem deixe que sujeira ou resíduos de líquido de limpeza se acumulem nas superfícies de vedação.
- (c) AVISO: Se a porta ou os vedantes da porta estiverem danificados, o forno não deve ser usado antes de ser reparado por uma pessoa competente.

TERMO ADITIVO

Se o aparelho não for mantido em boas condições de limpeza, a sua superfície pode degradar-se e afetar a vida útil do aparelho e causar uma situação perigosa.

ESPECIFICAÇÕES

Modelo:	MWE FS20 G WH
Tensão nominal:	230 V~ 50 Hz
Potência nominal de entrada (Microondas):	1050 W
Potência nominal de saída (Microondas):	700 W
Potência nominal de entrada (Grill):	1000 W

INSTRUÇÕES IMPORTANTES DE SEGURANÇA

AVISO

Para reduzir o risco de incêndio, choque elétrico, ferimentos em pessoas ou exposição à energia excessiva do forno micro-ondas quando usar o seu aparelho, siga as precauções básicas, incluindo as seguintes:

1. Leia e siga as instruções específicas: "PRECAUÇÕES PARA EVITAR POSSÍVEL EXPOSIÇÃO EXCESSIVA À ENERGIA DE MICRO-ONDAS".
2. Este aparelho pode ser usado por crianças com idade a partir dos 8 anos e pessoas com capacidades físicas, sensoriais ou mentais reduzidas ou falta de experiência e conhecimento, se tiverem recebido supervisão ou instrução sobre o uso do aparelho de uma forma segura e compreender os perigos envolvidos. As crianças não devem brincar com o aparelho. A limpeza e a manutenção pelo usuário não deve ser feitas por crianças, a menos que tenham mais de 8 anos e sejam supervisionadas. Crianças com menos de 8 anos de idade devem ser mantidas afastadas, a menos que sejam supervisionadas continuamente.
3. Mantenha o aparelho e o cabo de alimentação fora do alcance de crianças com menos de 8 anos.
4. Se o cabo de alimentação estiver danificado, deve ser substituído pelo fabricante, pelo agente de serviço ou pessoas igualmente qualificadas, a fim de evitar perigos.
5. AVISO: Certifique-se de que o aparelho está desligado antes de substituir a lâmpada para evitar a possibilidade de choque elétrico.
6. AVISO: É perigoso para qualquer pessoa não competente realizar qualquer operação de serviço ou reparo que envolva a remoção de uma tampa que forneça proteção contra exposição à energia de micro-ondas.
7. AVISO: Líquidos e outros alimentos não devem ser aquecidos em recipientes lacrados, pois podem explodir.

8. Quando aquecer alimentos em recipientes de plástico ou papel, preste atenção ao forno devido à possibilidade de ignição.
9. Use apenas utensílios adequados para uso em fornos de micro-ondas.
10. Se houver emissão de fumaça, desligue ou retire a ficha da tomada e mantenha a porta fechada para abafar as chamas.
11. O aquecimento de bebidas no micro-ondas pode resultar em ebulição eruptiva retardada, portanto, deve-se ter cuidado ao manusear o recipiente.
12. O conteúdo dos biberões e bociões de comida para bebé deve ser mexido ou agitado e a temperatura verificada antes do consumo, para evitar queimaduras.
13. Ovos com casca e ovos cozidos inteiros não devem ser aquecidos em fornos de micro-ondas, pois podem explodir, mesmo após o término do aquecimento por micro-ondas.
14. O forno deve ser limpo regularmente e quaisquer depósitos de alimentos removidos.
15. Não manter o forno limpo pode levar à deterioração da superfície, o que pode afetar adversamente a vida útil do aparelho e, possivelmente, resultar em uma situação perigosa.
16. O aparelho não deve ser instalado atrás de uma porta de decoração para evitar sobreaquecimento. (Não se aplica a aparelho com porta de decoração.)
17. Use apenas a sonda de temperatura recomendada para este forno. (Para fornos fornecidos com a possibilidade de ser usada uma sonda de detecção de temperatura.)
18. O forno microondas não deve ser colocado num armário a menos que tenha sido testado num armário.
19. O forno micro-ondas deve funcionar com a porta decorativa aberta. (para fornos com porta decorativa).

20. Este aparelho deve ser usado em aplicações domésticas e semelhantes, como:
- áreas de cozinha para funcionários em lojas, escritórios e outros ambientes de trabalho;
 - por clientes em hotéis, motéis e outros ambientes residenciais;
 - casas agrícolas;
 - ambientes tipo motéis.
21. O forno micro-ondas destina-se a aquecer alimentos e bebidas. A secagem de alimentos ou roupas e o aquecimento de almofadas, chinelos, esponjas, panos húmidos e semelhantes podem causar risco de ferimentos, ignição ou incêndio.
22. Recipientes metálicos para alimentos e bebidas não são permitidos durante o cozimento no micro-ondas.
23. O aparelho não deve ser limpo com máquinas de limpeza a vapor.
24. O aparelho destina-se a ser utilizado de forma independente.
25. A superfície traseira dos aparelhos deve ser colocada contra uma parede.

**LEIA COM ATENÇÃO E MANTENHA PARA
REFERÊNCIA FUTURA
APENAS PARA USO DOMÉSTICO.
(NÃO PARA USO COMERCIAL)**

PARA REDUZIR O RISCO DE FERIMENTOS A PESSOAS INSTALAÇÃO DE LIGAÇÃO DE TERRA PERIGO

Risco de choque elétrico

Tocar em alguns dos componentes internos pode causar ferimentos graves ou morte. Não desmonte este aparelho.

AVISO

Risco de choque elétrico - O uso inadequado da ligação de terra pode resultar em choque elétrico.

Não conecte em uma tomada até que o aparelho esteja devidamente instalado e a ligação de terra devidamente instalada. Este aparelho deve ter ligação de terra. No caso de um curto-circuito elétrico, o aterramento reduz o risco de choque elétrico, fornecendo um cabo de escape para a corrente elétrica. Este aparelho está equipado com um cabo de ligação à terra com uma ficha de ligação de terra. A ficha deve ser conectada a uma tomada devidamente instalada e com ligação de terra. Consulte um electricista ou técnico qualificado se as instruções de ligação de terra não forem totalmente compreendidas ou se houver dúvidas sobre se o aparelho está devidamente conectado a uma ligação de terra.

Se for necessário usar um cabo de extensão, use apenas um cabo de extensão de 3 conetores.

1. Um cabo de alimentação curto é fornecido para reduzir os riscos resultantes de ficar enrolado ou tropeçar em um cabo mais longo.
2. Se um conjunto de cabo longo ou cabo de extensão for usado:
 - 1) A classificação elétrica marcada do conjunto de cabos ou cabo de extensão deve ser pelo menos tão grande quanto a classificação elétrica do aparelho.
 - 2) O cabo de extensão deve ser um cabo de 3 conetores do tipo terra.
 - 3) O cabo longo deve ser disposto de forma que não caia sobre o balcão ou mesa, onde possa ser puxado por crianças ou tropeçado involuntariamente.

LIMPEZA

Certifique-se de desconectar o aparelho da fonte de alimentação.

1. Limpe a cavidade do forno após o uso com um pano levemente húmido.
2. Limpe os acessórios da forma habitual em água com sabão.
3. A moldura da porta e a vedação e as partes adjacentes devem ser limpas cuidadosamente com um pano húmido quando estiverem sujas.
4. Não use produtos de limpeza abrasivos ou raspadores de metal afiados para limpar o vidro da porta do forno, pois eles podem arranhar a superfície, o que pode resultar na quebra do vidro.
5. Dica de limpeza --- Para uma limpeza mais fácil das paredes da cavidade nos quais alimentos cozidos possam tocar: Coloque meio limão em uma tigela, adicione 300ml (1/2 litro) de água e aqueça 100% no micro-ondas por 10 minutos. Limpe o forno com um pano macio e seco.

UTENSÍLIOS

CUIDADO

Risco de lesão corporal

É perigoso para qualquer pessoa que não seja competente realizar qualquer operação de serviço ou reparo que envolva a remoção de uma tampa que forneça proteção contra a exposição à energia de micro-ondas.

Veja as instruções em "Materiais que pode usar no forno de micro-ondas ou que devem ser evitados no forno de micro-ondas."

Pode haver certos utensílios não metálicos que não são seguros para micro-ondas. Em caso de dúvida, pode testar o utensílio em questão seguindo o procedimento abaixo.

Teste de utensílios:

1. Encha um recipiente adequado para micro-ondas com 1 xícara de água fria (250ml) junto com o utensílio em questão.
2. Cozinhe na potência máxima por 1 minuto.
3. Toque cuidadosamente o utensílio. Se o utensílio vazio estiver quente, não o utilize para cozinhar no micro-ondas.
4. Não exceda 1 minuto de tempo de cozimento

Materiais que você pode usar no forno de micro-ondas

Utensílios	Observações
Prato para tostar	Siga as instruções do fabricante. O fundo do prato para tostar deve estar pelo menos 5 mm (3/16 inch) acima do prato giratório. O uso incorreto pode causar a quebra da plataforma giratória.
Louça	Use apenas louça própria para micro-ondas. Siga as instruções do fabricante. Não use pratos rachados ou lascados.
Jarras de vidro	Remova sempre a tampa. Use apenas para aquecer os alimentos até ficarem mornos. A maioria dos jarras de vidro não são resistentes ao calor e podem quebrar.
Recipientes de vidro	Usar apenas recipientes de vidro resistentes ao calor. Certifique-se de que não haja acabamento metálico. Não use pratos rachados ou lascados.
Sacos para cozinhar para forno	Siga as instruções do fabricante. Não feche os sacos plásticos com laço de metal. Faça fendas para permitir que o vapor escape.
Pratos e copos de papel	Use apenas para cozinhar / aquecer por um período curto. Não deixe o forno sem vigilância durante o cozimento.
Toalhas de papel	Use para cobrir alimentos para reaquecimento e absorção de gordura. Use com supervisão e apenas para um cozimento de curto prazo.
Papel pergaminho	Use como uma capa para evitar respingos ou como um envoltório para cozinhar.
Plástico	Usar apenas plástico próprio para micro-ondas. Siga as instruções do fabricante. Deve ser rotulado como "Microwave Safe" (seguro para micro-ondas). Alguns recipientes de plástico amolecem à medida que os alimentos dentro deles ficam quentes. "Sacos de fervura" e sacos de plástico bem fechados devem ser cortados, perfurados ou ventilados de acordo com as instruções da embalagem.
Envoltório plástico	Usar apenas plástico de embrulho próprio para micro-ondas. Use para cobrir os alimentos durante o cozimento para reter a umidade. Não deixe que o plástico encoste nos alimentos.
Termômetros	Somente termômetros para micro-ondas (termômetros de carne e doces).
Papel de cera	Use como uma cobertura para evitar respingos e reter a umidade.

Materiais a serem evitados no forno de micro-ondas

Utensílios	Observações
Bandeja de alumínio	Pode causar desformação e dobragem. Transfira os alimentos para um prato adequado para micro-ondas.
Caixa de alimentos com alça de metal	Pode causar desformação e dobragem. Transfira os alimentos para um prato adequado para micro-ondas.
Utensílios de metal ou aparados em metal	O metal protege a comida da energia de microondas. O acabamento de metal pode causar desformação e dobrar.
Objetos com torção de metal	Pode causar desformação e dobragem e pode causar um incêndio no forno.
Sacos de papel	Pode causar um incêndio no forno.
Espuma plástica	A espuma plástica pode derreter ou contaminar o líquido interno quando exposta a altas temperaturas.
Madeira	A madeira pode secar quando usada no forno de micro-ondas e pode rachar.

NOMES DAS PARTES E ACESSÓRIOS DO FORNO

(No caso de qualquer diferença entre o aparelho e as imagens neste manual, o produto prevalecerá.)

Retire o forno e todos os materiais da caixa e da cavidade do forno.
Seu forno vem com os seguintes acessórios:

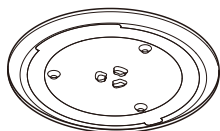

Prato de Vidro



Conjunto do Anel do Prato Giratório

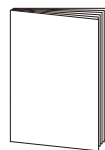

Manual de Instruções



Eixo do Prato Giratório

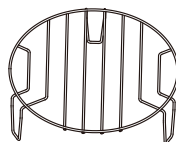

Grelha (Não pode ser usada na função micro-ondas e deve ser colocada no prato de vidro)

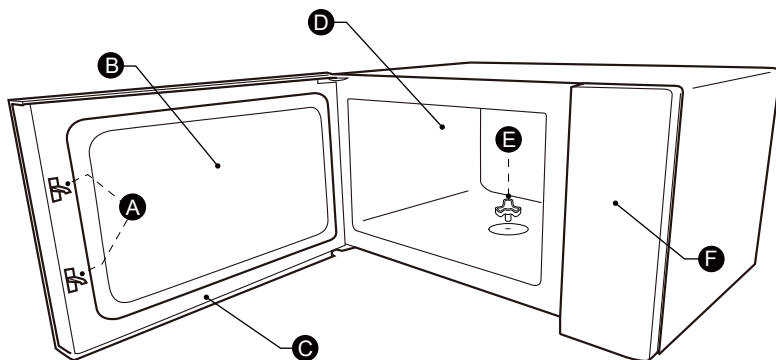

- A) Sistema de travamento de segurança
- B) Janela de observação
- C) Conjunto da porta

- D) Cavidade do forno
- E) Eixo do prato giratório
- F) Painel de controle

INSTALAÇÃO DO PRATO GIRATÓRIO

Limpe o compartimento de cozimento e coloque o prato giratório no lugar. Para novas instalações, certifique-se de que toda a embalagem e fita de envio foram removidas do eixo do prato giratório. Antes de usar o aparelho para preparar alimentos pela primeira vez, você precisará colocar o prato giratório corretamente. Você deve limpar o compartimento de cozimento e os acessórios.

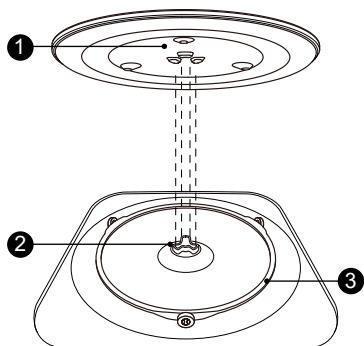

Como colocar o prato giratório no lugar:

1. Coloque o conjunto do anel do prato giratório (3) no recesso do compartimento de cozimento.
 2. Coloque o prato de vidro (1) no conjunto do anel do prato giratório (3). Encaixe as linhas curvas elevadas no centro da parte inferior do prato de vidro entre os três raios do eixo.
- Certifique-se de que o prato de vidro (1) se engate no eixo do prato giratório (2) no centro do piso do compartimento de cozimento. Os rolos no eixo devem se encaixar dentro da borda inferior do prato giratório.

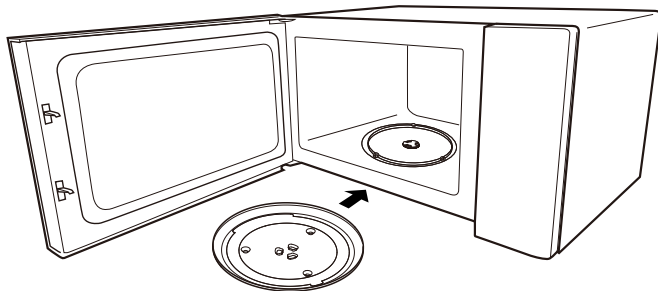

Notas:

1. Nunca use o aparelho sem o prato giratório. Certifique-se de que está devidamente encaixado. O prato giratório pode girar no sentido horário ou anti-horário.
2. Nunca coloque o prato de vidro de cabeça para baixo. O prato de vidro nunca deve ser restringido.
3. Tanto o prato de vidro quanto o conjunto do anel do prato giratório devem sempre ser usados durante o cozimento.
4. Todos os alimentos e recipientes de alimentos devem sempre ser colocados no prato de vidro para cozinhar.
5. Nunca restrinja o movimento do prato giratório.
6. Se o prato de vidro ou o conjunto do anel do prato giratório rachar ou quebrar, entre em contato com o centro de serviço autorizado mais próximo.

Instalação de Bancada

Remova todo o material de embalagem e acessórios. Verifique se há algum dano no forno, como amassados ou porta quebrada. Não instale se o forno estiver danificado.

Gabinete: Remova qualquer filme protetor encontrado na superfície do gabinete do micro-ondas. Não remova a tampa da guia de ondas que está presa à cavidade do forno para proteger o magnetron

Instalação

1. Selecione uma superfície nivelada que forneça espaço aberto suficiente para as aberturas de entrada e/ou saída de ar.

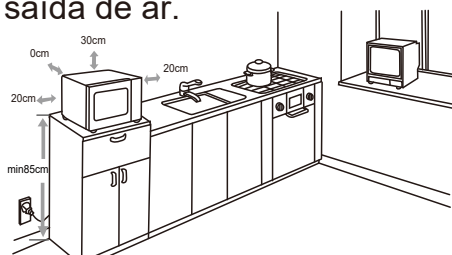

(1) A altura mínima de instalação é de 85 cm.

(2) A superfície traseira do aparelho deve ser colocada contra uma parede.

Deixe uma folga mínima de 30 cm acima do forno, e uma folga mínima de 20 cm é necessária entre o forno e quaisquer paredes adjacentes.

(3) Não remova os pés da parte inferior do forno.

(4) Bloquear as aberturas de entrada e/ou saída pode danificar o forno.

(5) Coloque o forno o mais longe possível de rádios e TVs. A operação do forno micro-ondas pode causar interferência na recepção do rádio ou da TV.

2. Conecte seu forno a uma tomada doméstica padrão. Certifique-se de que a voltagem e a frequência são as mesmas da voltagem e da frequência indicadas na etiqueta de classificação.

AVISO: Não instale o forno sobre um fogão ou outro aparelho que produza calor. Se instalado próximo ou sobre uma fonte de calor, o forno pode ser danificado e a garantia será anulada.

A superfície acessível pode estar quente durante a operação.



Painel de Controle

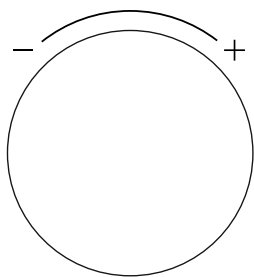
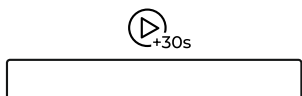
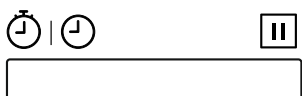
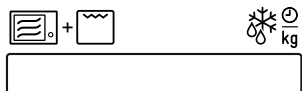

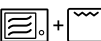
 Function
(Micro-ondas+Grill+Combi)

 Descongelo por
Peso/Descongelo por Tempo







 Timer/Relógio

 Parar/Cancelar



 Iniciar/+30Seg./Cozimento Rápido

OPERAÇÃO



1. Configuração do Relógio

- (1) Pressione “ |  ” duas vezes e então “00:00” será exibido.
- (2) Gire o botão para ajustar as horas.
- (3) Pressione “ |  ” para confirmar.
- (4) Gire o botão para ajustar os minutos.
- (5) Pressione “ |  ” para confirmar. O relógio está ajustado.

Notas:

- (1) O relógio é um display de 24 horas. Se o relógio não estiver ajustado, ele não funcionará quando ligado.
- (2) Para reajustar o relógio, repita o passo 1 ao passo 5.
- (3) Após ajustar o relógio, se “ |  ” não for pressionado ou se não houver operação de 1 dentro minuto, a configuração será inválida.

2. Configuração do Timer da Cozinha







- (1) Pressione “ |  ” uma vez e então “0:00” será exibido.
- (2) Gire o botão para definir o tempo desejado. O valor máximo de tempo é “95:00”.
- (3) Pressione “ ” para confirmar. O timer começará a contagem regressiva.

Nota: O timer da cozinha é um timer.

3. Cozimento no Micro-ondas

Tabela de Potência do Micro-ondas

Potência do Micro-ondas	100%	80%	50%	30%	10%
Exibição	P100	P80	P50	P30	P10

- (1) Pressione “ +  ” uma vez e então “P100” será exibido.
- (2) Pressione “ +  ” repetidamente ou gire o botão para definir o nível de potência. Existem 5 níveis de potência disponíveis.
- (3) Pressione “ ” para confirmar.
- (4) Gire o botão para definir o tempo de cozimento. O valor máximo de tempo é “95:00”.
- (5) Pressione “ ” para iniciar o cozimento.

4. Descongelar por Peso

(1) Pressione “  ” uma vez, a tela exibirá “dEF1”.

(2) Gire o botão para definir o peso do alimento. A faixa de peso é de 100 a 2000g. .

(3) Pressione “  ” para iniciar o descongelamento.

Nota: O alarme soará para lembrá-lo de virar o alimento durante o descongelamento. Se não houver operação, o forno continuará funcionando.

5. Descongelar por Tempo

(1) Pressione “  ” duas vezes, a tela exibirá “dEF2”.

(2) Gire o botão para definir o tempo desejado de descongelamento. O valor máximo de tempo é “95:00”.

(3) Pressione “  ” para iniciar o descongelamento.

Notas:

(1) O alarme soará para lembrá-lo de virar o alimento durante o descongelamento. Se não houver operação, o forno continuará funcionando.

(2) A potência de descongelamento é P30 e não pode ser alterada.

6. Cozimento Rápido

(1) No modo de espera, pressione “  ” para cozinhar alimentos com 100% de potência por 30 segundos. Cada pressão na mesma tecla pode aumentar 30 segundos e o valor máximo de tempo é “95:00”.

(2) No modo de espera, gire o botão para a esquerda para definir um tempo de cozimento com 100% de potência. Continue girando o botão para ajustar o tempo de cozimento. O valor máximo de tempo é “95:00”. Em seguida, pressione “  ” para iniciar o cozimento.

Nota: No estado de cozimento e no estado de descongelamento por tempo, cada pressão adicional em “  ” pode aumentar o tempo de cozimento em 30 segundos (exceto para descongelamento por peso, o menu automático e a primeira etapa do cozimento multi-etapas).







7. Cozimento Multi-Etapas

Notas: (1) Duas etapas de cozimento podem ser configuradas no cozimento multi-etapas.







(2) Se você configurar a função de descongelamento, ela funcionará automaticamente na primeira etapa.

(3) O timer da cozinha, o menu automático não podem ser configurados como uma das multi-etapas.

Exemplo: Descongele alimentos por 5 minutos e depois cozinhe com 80% de potência do micro-ondas por 7 minutos.

- (1) Pressione “ ” duas vezes, a tela exibirá “dEF2”.
- (2) Gire o botão para definir o tempo desejado de descongelamento para 5 minutos.
- (3) Pressione “ +  ” uma vez e então “P100” será exibido.
- (4) Pressione “ +  ” novamente ou gire o botão para definir o nível de potência para P80.
- (5) Pressione “ ” para confirmar.
- (6) Gire o botão para definir o tempo de cozimento para 7 minutos.
- (7) Pressione “ ” para iniciar o cozimento.

8. Cozimento com Grill e Combinado

- (1) Pressione “ +  ” uma vez e então “P100” será exibido.
- (2) Pressione “ +  ” repetidamente ou gire o botão até que “G-1”, “C-1” e “C-2” sejam exibidos em ordem.
- (3) Pressione “ ” para confirmar.
- (4) Gire o botão para definir o tempo de cozimento. O valor máximo de tempo é “95:00”.
- (5) Pressione “ ” para iniciar o cozimento.

Nota: O alarme soará para lembrá-lo de virar o alimento durante o cozimento na grelha. Se não houver operação, o forno continuará funcionando.

Tabela de Cozimento Combinado

Função	Exibição	Potência do Micro-ondas	Potência da Grelha
Combi. 1	C-1	55%	45%
Combi. 2	C-2	36%	64%

9. Menu Automático



- (1) Gire o botão para a direita e então "A-1" será exibido.
- (2) Continue girando o botão para escolher o menu desejado. Estão disponíveis 8 menus automáticos.
- (3) Pressione "  +30s " para confirmar.
- (4) Gire o botão para definir o peso do alimento.
- (5) Pressione "  +30s " para iniciar o cozimento.

Tabela do Menu Automático

Menu	Peso	Exibição	Potência
A-1 Reaquecimento Automático	200g	200	P100
	400g	400	
	600g	600	
A-2 Vegetais	300g	300	P100
	400g	400	
A-3 Peixe	250g	250	P80
	350g	350	
	450g	450	
A-4 Carne	250g	250	P100
	350g	350	
	450g	450	
A-5 Massa	50g (com 450g de água fria)	50	P80
	100g (com 800g de água fria)	100	
A-6 Batata	200g	200	P100
	400g	400	
	600g	600	
A-7 Pizza	200g	200	P100
	400g	400	
A-8 Sopa	200ml	200	P100
	400ml	400	

10. Função de Bloqueio para Crianças

Você pode usar esta função para evitar que as crianças liguem o forno acidentalmente.



Para ativar o bloqueio:



No modo de espera, pressione e segure “” por três segundos. Um longo bip soará e “” será exibido.

Para desativar o bloqueio:

No estado bloqueado, pressione e segure “” por três segundos. Um longo bip soará.

11. Função de Consulta

(1) Se o relógio estiver ajustado, a hora atual será exibida por três segundos ao pressionar “ | ” no estado de cozimento.

(2) No estado de micro-ondas, grill, ou cozimento combinado, pressione “ + ” para consultar o nível de potência ou modo de cozimento. Ele será exibido por três segundos.

Solução de problemas

Normal	
O forno micro-ondas interfere com a recepção da TV.	A recepção de rádio e TV pode sofrer interferências durante o funcionamento do forno de micro-ondas. É semelhante à interferência de pequenos aparelhos elétricos, como bateadeira, aspirador de pó e ventilador elétrico. É normal.
Forno com luz mais fraca.	No cozimento de micro-ondas de baixa potência, a luz do forno pode ficar fraca. É normal.
Vapor acumula-se na porta, ar quente saindo das aberturas.	Ao cozinhar, pode sair vapor dos alimentos. A maioria sairá da porta do forno. É normal.
O forno foi ligado acidentalmente sem nenhum alimento.	É proibido operar a unidade sem nenhum alimento no interior. É muito perigoso.

Problema	Possível causa	Solução
O forno não pode ser iniciado.	(1) O cabo de alimentação não está conectado corretamente.	Desconecte. Em seguida, conecte novamente após 10 segundos.
	(2) Fusível queimado ou disjuntor não funciona	Substitua o fusível ou reinicie o disjuntor (reparado por profissionais da nossa empresa)
	(3) Problemas com a tomada.	Teste a tomada com outros aparelhos elétricos.
Forno não aquece.	(4) A porta não está bem fechada.	Feche bem a porta.

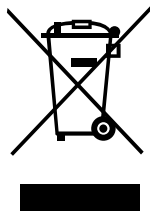

De acordo com a diretiva de Resíduos de Equipamentos Elétricos e Eletrônicos (WEEE), os WEEE devem ser coletados e tratados separadamente. Se em algum momento no futuro você precisar descartar este produto, NÃO o descarte junto com o lixo doméstico. Envie este produto para pontos de coleta de WEEE, onde disponível.

Microwave Oven

INSTRUCTION MANUAL

Model: MWE FS20 G WH

Read these instructions carefully before using your microwave oven, and keep it carefully.

If you follow the instructions, your oven will provide you with many years of good service.

SAVE THESE INSTRUCTIONS CAREFULLY

PRECAUTIONS TO AVOID POSSIBLE EXPOSURE TO EXCESSIVE MICROWAVE ENERGY

- (a) Do not attempt to operate this oven with the door open since this can result in harmful exposure to microwave energy. It is important not to break or tamper with the safety interlocks.
- (b) Do not place any object between the oven front face and the door or allow soil or cleaner residue to accumulate on sealing surfaces.
- (c) **WARNING:** If the door or door seals are damaged, the oven must not be operated until it has been repaired by a competent person.

ADDENDUM

If the apparatus is not maintained in a good state of cleanliness, its surface could be degraded and affect the lifespan of the apparatus and lead to a dangerous situation.

SPECIFICATIONS

Model	MWE FS20 G WH
Rated Voltage/Frequency	230 V~ 50 Hz
Microwave Input	1050 W
Microwave Output	700 W
Grill	1000 W

IMPORTANT SAFETY INSTRUCTIONS

WARNING

To reduce the risk of fire, electric shock, injury to persons or exposure to excessive microwave oven energy when using your appliance, follow basic precautions, including the following:

1. Read and follow the specific: "PRECAUTIONS TO AVOID POSSIBLE EXPOSURE TO EXCESSIVE MICROWAVE ENERGY".
2. This appliance can be used by children aged from 8 years and above and persons with reduced physical, sensory or mental capabilities or lack of experience and knowledge if they have been given supervision or instruction concerning use of the appliance in a safe way and understand the hazards involved. Children shall not play with the appliance. Cleaning and user maintenance shall not be made by children without supervision.
3. Keep the appliance and its cord out of reach of children less than 8 years.
4. If the supply cord is damaged, it must be replaced by the manufacturer, its service agent or similarly qualified persons in order to avoid a hazard.
5. **WARNING:** Ensure that the appliance is switched off before replacing the lamp to avoid the possibility of electric shock.
6. **WARNING:** It is hazardous for anyone other than a competent person to carry out any service or repair operation that involves the removal of a cover which gives protection against exposure to microwave energy.
7. **WARNING:** Liquids and other foods must not be heated in sealed containers since they are liable to explode.
8. When heating food in plastic or paper containers, keep

- an eye on the oven due to the possibility of ignition.
9. Only use utensils that are suitable for use in microwave ovens.
 10. If smoke is emitted, switch off or unplug the appliance and keep the door closed in order to stifle any flames.
 11. Microwave heating of beverages can result in delayed eruptive boiling, therefore care must be taken when handling the container.
 12. The contents of feeding bottles and baby food jars shall be stirred or shaken and the temperature checked before consumption, in order to avoid burns.
 13. Eggs in their shell and whole hard-boiled eggs should not be heated in microwave ovens since they may explode, even after microwave heating has ended.
 14. The oven should be cleaned regularly and any food deposits removed.
 15. Failure to maintain the oven in a clean condition could lead to deterioration of the surface that could adversely affect the life of the appliance and possibly result in a hazardous situation.
 16. The appliance must not be installed behind a decorative door in order to avoid overheating. (This is not applicable for appliances with decorative door.)
 17. Only use the temperature probe recommended for this oven. (for ovens provided with a facility to use a temperature-sensing probe.)
 18. The microwave oven shall not be placed in a cabinet unless it has been tested in a cabinet.
 19. The microwave oven must be operated with the decorative door open. (for ovens with a decorative door.)

20. This appliance is intended to be used in household and similar applications such as:
 - staff kitchen areas in shops, offices and other working environments;
 - by clients in hotels, motels and other residential type environments;
 - farm houses;
 - bed and breakfast type environments.
21. The microwave oven is intended for heating food and beverages. Drying of food or clothing and heating of warming pads, slippers, sponges, damp cloth and similar may lead to risk of injury, ignition or fire.
22. Metallic containers for food and beverages are not allowed during microwave cooking.
23. The appliance shall not be cleaned with a steam cleaner.
24. The appliance is intended to be used freestanding.
25. The rear surface of appliances shall be placed against a wall.

**READ CAREFULLY AND KEEP FOR FUTURE
REFERENCE
HOUSEHOLD USE ONLY
(NOT FOR COMMERCIAL USE)**

TO REDUCE THE RISK OF INJURY TO PERSONS GROUNDING INSTALLATION

DANGER

Electric Shock Hazard

Touching some of the internal components can cause serious personal injury or death. Do not disassemble this appliance.

WARNING

Electric Shock Hazard

Improper use of the grounding can result in electric shock.

Do not plug into an outlet until appliance is properly installed and grounded.

This appliance must be grounded. In the event of an electrical short circuit, grounding reduces the risk of electric shock by providing an escape wire for the electric current.

This appliance is equipped with a cord having a grounding wire with a grounding plug. The plug must be plugged into an outlet that is properly installed and grounded.

Consult a qualified electrician or serviceman if the grounding instructions are not completely understood or if doubt exists as to whether the appliance is properly grounded.

If it is necessary to use an extension cord, use only a 3-wire extension cord.

1. A short power-supply cord is provided to reduce the risks resulting from becoming entangled in or tripping over a longer cord.
2. If a long cord set or extension cord is used:
 - 1) The marked electrical rating of the cord set or extension cord should be at least as great as the electrical rating of the appliance.
 - 2) The extension cord must be a grounding-type 3-wire cord.
 - 3) The long cord should be arranged so that it will not drape over the counter top or tabletop where it can be pulled on by children or tripped over unintentionally.

CLEANING

Be sure to unplug the appliance from the power supply.

1. Clean the cavity of the oven after using with a slightly damp cloth.
2. Clean the accessories in the usual way in soapy water.
3. The door frame and seal and neighbouring parts must be cleaned carefully with a damp cloth when they are dirty.
4. Do not use harsh abrasive cleaners or sharp metal scrapers to clean the oven door glass since they can scratch the surface, which may result in shattering of the glass.
5. Cleaning Tip---For easier cleaning of the cavity walls that the food cooked can touch: Place half a lemon in a bowl, add 300ml (1/2 pint) water and heat on 100% microwave power for 10 minutes. Wipe the oven clean using a soft, dry cloth.

UTENSILS

CAUTION

Personal Injury Hazard

It is hazardous for anyone other than a competent person to carry out any service or repair operation that involves the removal of a cover which gives protection against exposure to microwave energy.

See the instructions on "Materials you can use in microwave oven or to be avoided in microwave oven." There may be certain non-metallic utensils that are not safe to use for microwaving. If in doubt, you can test the utensil in question following the procedure below.

Utensil Test:

1. Fill a microwave-safe container with 1 cup of cold water (250ml) along with the utensil in question.
2. Cook on maximum power for 1 minute.
3. Carefully feel the utensil. If the empty utensil is warm, do not use it for microwave cooking.
4. Do not exceed 1 minute cooking time.

Materials you can use in microwave oven

Utensils	Remarks
Browning dish	Follow manufacturer's instructions. The bottom of browning dish must be at least 3/16 inch (5mm) above the turntable. Incorrect usage may cause the turntable to break.
Dinnerware	Microwave-safe only. Follow manufacturer's instructions. Do not use cracked or chipped dishes.
Glass jars	Always remove lid. Use only to heat food until just warm. Most glass jars are not heat resistant and may break.
Glassware	Heat-resistant oven glassware only. Make sure there is no metallic trim. Do not use cracked or chipped dishes.
Oven cooking bags	Follow manufacturer's instructions. Do not close with metal tie. Make slits to allow steam to escape.
Paper plates and cups	Use for short-term cooking/warming only. Do not leave oven unattended while cooking.
Paper towels	Use to cover food for reheating and absorbing fat. Use with supervision for a short-term cooking only.
Parchment paper	Use as a cover to prevent splattering or a wrap for steaming.
Plastic	Microwave-safe only. Follow the manufacturer's instructions. Should be labeled "Microwave Safe". Some plastic containers soften, as the food inside gets hot. "Boiling bags" and tightly closed plastic bags should be slit, pierced or vented as directed by package.
Plastic wrap	Microwave-safe only. Use to cover food during cooking to retain moisture. Do not allow plastic wrap to touch food.
Thermometers	Microwave-safe only (meat and candy thermometers).
Wax paper	Use as a cover to prevent splattering and retain moisture.

Materials to be avoided in microwave oven

Utensils	Remarks
Aluminum tray	May cause arcing. Transfer food into microwave-safe dish.
Food carton with metal handle	May cause arcing. Transfer food into microwave-safe dish.
Metal or metal-trimmed utensils	Metal shields the food from microwave energy. Metal trim may cause arcing.
Metal twist ties	May cause arcing and could cause a fire in the oven.
Paper bags	May cause a fire in the oven.
Plastic foam	Plastic foam may melt or contaminate the liquid inside when exposed to high temperature.
Wood	Wood will dry out when used in the microwave oven and may split or crack.

NAMES OF OVEN PARTS AND ACCESSORIES

(In case of any differences between the appliance and the pictures in this manual, the product shall prevail.)

Remove the oven and all materials from the carton and oven cavity.
Your oven comes with the following accessories:

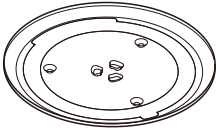

Glass Tray



Turntable Ring Assembly



Instruction Manual



Turntable Shaft

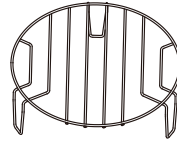

Grill Rack(Can not be used in microwave function and must be placed on the glass tray)

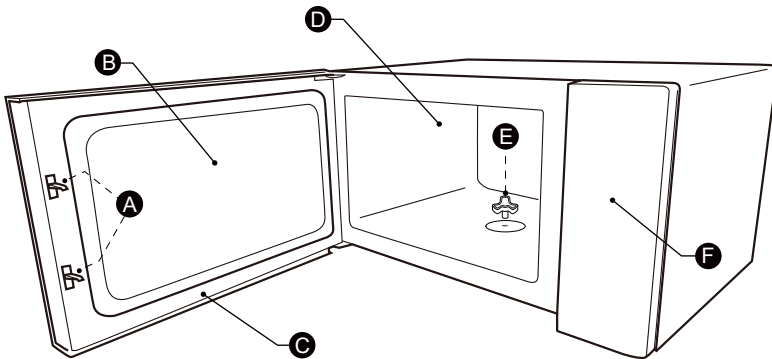

- A) Safety interlock system
- B) Observation window
- C) Door assembly

- D) Oven cavity
- E) Turntable shaft
- F) Control panel

TURNTABLE INSTALLATION

Cleaning the cooking compartment and putting the turntable in place. For new installations, make sure all packaging and shipping tape has been removed from the turntable shaft. Before using the appliance to prepare food for the first time, you will need to put the turntable in place correctly. You must clean the cooking compartment and accessories.

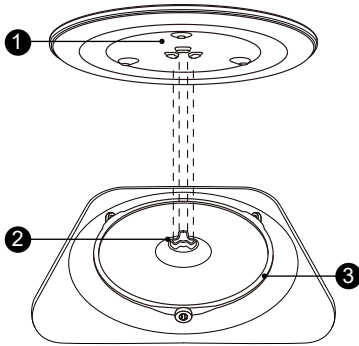

How to put the turntable in place:

1. Place the turntable ring assembly ③ into the recess in the cooking compartment.
2. Place the glass tray ① on the turntable ring assembly ③. Fit the raised, curved lines in the center of the glass tray bottom between the three spokes of the shaft. Make sure that the glass tray ① engages in the turntable shaft ② in the centre of the cooking compartment floor. The rollers on the shaft should fit inside the turntable bottom ridge.

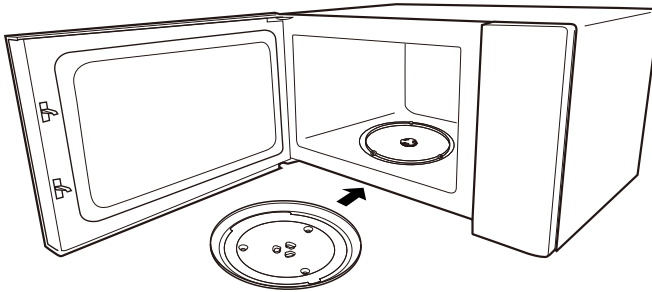

Notes:

1. Never use the appliance without the turntable. Make sure that it is properly engaged. The turntable can turn clockwise or anti-clockwise.
2. Never place the glass tray upside down. The glass tray should never be restricted.
3. Both glass tray and turntable ring assembly must always be used during cooking.
4. All food and containers of food are always placed on the glass tray for cooking.
5. Never restrict the movement of the turntable.
6. If glass tray or turntable ring assembly cracks or breaks, contact your nearest authorized service center.

Countertop Installation

Remove all packing material and accessories. Examine the oven for any damage such as dents or broken door. Do not install if oven is damaged.

Cabinet: Remove any protective film found on the microwave oven cabinet surface. Do not remove the waveguide cover that is attached to the oven cavity to protect the magnetron.

Installation

1. Select a level surface that provide enough open space for the intake and/or outlet vents.

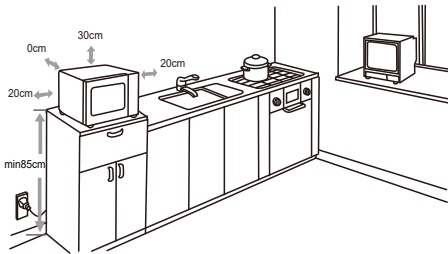

(1) The minimum installation height is 85cm.

(2) The rear surface of appliance shall be placed against a wall.

Leave a minimum clearance of 30cm above the oven, a minimum clearance of 20cm is required between the oven and any adjacent walls.

(3) Do not remove the legs from the bottom of the oven.

(4) Blocking the intake and/or outlet openings can damage the oven.

(5) Place the oven as far away from radios and TV as possible. Operation of microwave oven may cause interference to your radio or TV reception.

2. Plug your oven into a standard household outlet. Be sure the voltage and the frequency is the same as the voltage and the frequency on the rating label.





WARNING: Do not install oven over a range cooktop or other heat-producing appliance. If installed near or over a heat source, the oven could be damaged and the warranty would be void.

The accessible surface may be hot during operation.

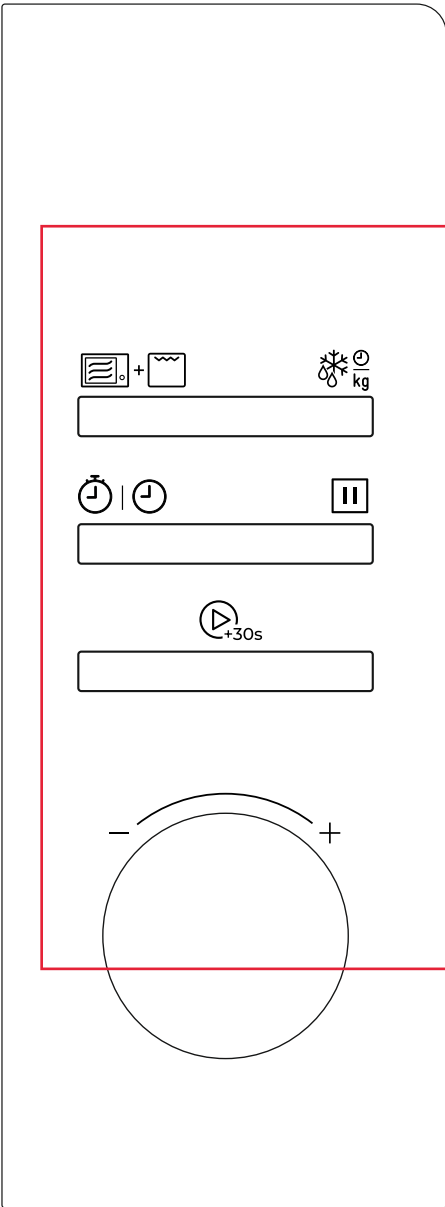

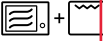





Control Panel





-  Function (Microwave+Grill+Combi)
-  Defrost by Weight/Defrost by Time
-  Timer/Clock
-  Stop/Cancel
-  Start/+30Sec./Speedy Cooking

OPERATION



1. Setting the Clock

- (1) Press "  |  " twice and then "00:00" will display.
- (2) Turn the knob to set the hour figures.
- (3) Press "  |  " to confirm.
- (4) Turn the knob to set the minute figures.
- (5) Press "  |  " to confirm. The clock is set.

Notes:

- (1) The clock is a 24-hour display. If the clock is not set, it will not work when powered.
- (2) To reset the clock, please repeat step 1 to step 5.
- (3) After setting the clock, if "  |  " is not pressed or if there is no operation within 1 minute, the setting is invalid.

2. Setting the Kitchen Timer







- (1) Press "  |  " once and then "0:00" will display.
- (2) Turn the knob to set the desired time. The maximum time value is "95:00".
- (3) Press "  _{+30s} " to confirm. The timer starts counting down.

Note: The kitchen timer is a timer.



3. Microwave Cooking

Microwave Power Chart

Microwave Power	100%	80%	50%	30%	10%
Display	P100	P80	P50	P30	P10



- (1) Press "  +  " once and then "P100" will display.
- (2) Press "  +  " repeatedly or turn the knob to set the power level. The 5 power levels are available.
- (3) Press "  _{+30s} " to confirm.
- (4) Turn the knob to set the cooking time. The maximum time value is "95:00".
- (5) Press "  _{+30s} " to start cooking.

4. Defrost By Weight

- (1) Press "  " once, the screen will display "dEF1".
- (2) Turn the knob to set the weight of the food. The range of weight is 100-2000g.
- (3) Press "  " to start defrosting

Note: The buzzer will sound to remind you to turn the food over during defrosting.
If no operation, the oven will continue working.



5. Defrost By Time

- (1) Press "  " twice, the screen will display "dEF2".
- (2) Turn the knob to set the desired defrost time. The maximum time value is "95:00".
- (3) Press "  " to start defrosting.

Notes:

- (1) The buzzer will sound to remind you to turn the food over during defrosting.
If no operation, the oven will continue working.
- (2) The defrost power is P30 and it cannot be changed.

6. Speedy Cooking

- (1) In standby mode, press "  " to cook food at 100% power level for 30 seconds.
Each press on the same key can increase 30 seconds and the maximum time value is "95:00".
- (2) In standby mode, turn the knob left to set a cooking time with 100% power.
Continue to turn the knob to adjust the cooking time. The maximum time value is "95:00". Then press "  " to start cooking.

Note: In the cooking state and defrosting by time state, each more press on "  " can increase the cooking time by 30 seconds (except for defrosting by weight, the auto menu, and the first stage of multi-stage cooking).







7. Multi-Stage Cooking

Notes: (1) Two cooking stages can be set in multi-stage cooking.







(2) If you set the defrost function, it will work automatically in the first stage.

(3) The kitchen timer, auto menu cannot be set as one of the multi-stage.

Example: Defrost food for 5 minutes and then cook with 80% microwave power for 7 minutes.

- (1) Press "  " twice, the screen will display "dEF2".
- (2) Turn the knob to set the desired defrost time to 5 minutes.
- (3) Press "  +  " once and then "P100" will display.
- (4) Press "  +  " again or turn the knob to set the power level to P80.
- (5) Press "  " to confirm.
- (6) Turn the knob to set the cooking time to 7 minutes.
- (7) Press "  " to start cooking.

8. Grill and Combination Cooking

- (1) Press "  +  " once and then "P100" will display.
- (2) Press "  +  " repeatedly or turn the knob until "G-1", "C-1", and "C-2" displays in order.
- (3) Press "  " to confirm.
- (4) Turn the knob to set the cooking time. The maximum time value is "95:00".
- (5) Press "  " to start cooking.



Note: The buzzer will sound to remind you to turn the food over during grill cooking.

If no operation, the oven will continue working.

Combination Cooking Chart

Function	Display	Microwave Power	Grill Power
Combi. 1	C-1	55%	45%
Combi. 2	C-2	36%	64%

9. Auto Menu

- (1) Turn the knob right and then "A-1" will display.
- (2) Continue to turn the knob to choose the menu you need. The 8 auto menus are available.
- (3) Press "  " to confirm.
- (4) Turn the knob to set the weight of the food.
- (5) Press "  " to start cooking.



Auto Menu Chart

Menu	Weight	Display	Power
A-1 Auto Reheat	200g	200	P100
	400g	400	
	600g	600	
A-2 Vegetable	300g	300	P100
	400g	400	
A-3 Fish	250g	250	P80
	350g	350	
	450g	450	
A-4 Meat	250g	250	P100
	350g	350	
	450g	450	
A-5 Pasta	50g(with 450g cold water)	50	P80
	100g(with 800g cold water)	100	
A-6 Potato	200g	200	P100
	400g	400	
	600g	600	
A-7 Pizza	200g	200	P100
	400g	400	
A-8 Soup	200ml	200	P100
	400ml	400	

10. Lock-out Function for Children

You can use this function to prevent children from accidentally turning the oven on.





To activate the lock:

In standby mode, press and hold "  " for three seconds. A long beep sounds and "  " will display.

To deactivate the lock:

In the locked state, press and hold "  " for three seconds. A long beep sounds.

11. Inquiring Function

- (1) If the clock has been set, the current time will display for three seconds by pressing "  |  " in the cooking state.
- (2) In the microwave, grill, combination cooking state, press "  +  " to inquire about the power level or cooking mode. It will display for three seconds.

Trouble shooting

Normal	
Microwave oven interfering TV reception	Radio and TV reception may be interfered when microwave oven operating. It is similar to the interference of small electrical appliances, like mixer, vacuum cleaner, and electric fan. It is normal.
Dim oven light	In low power microwave cooking, oven light may become dim. It is normal.
Steam accumulating on door, hot air out of vents	In cooking, steam may come out of food. Most will get out from vents. But some may accumulate on cool place like oven door. It is normal.
Oven started accidentally with no food in.	It is forbidden to run the unit without any food inside. It is very dangerous.

Trouble	Possible Cause	Remedy
Oven cannot be started.	(1) Power cord is not plugged in tightly.	Unplug. Then plug again after 10 seconds.
	(2) Fuse blowing or circuit breaker works.	Replace fuse or reset circuit breaker (repaired by professional personnel of our company)
	(3) Trouble with outlet.	Test outlet with other electrical appliances.
Oven does not heat.	(4) Door is not closed well.	Close door well.

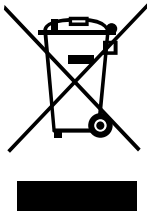

According to Waste of Electrical and Electronic Equipment (WEEE) directive, WEEE should be separately collected and treated. If at any time in future you need to dispose of this product please do NOT dispose of this product with household waste. Please send this product to WEEE collecting points where available.

Four à micro-ondes

MANUEL D'UTILISATION

Modèle: MWE FS20 G WH

Lire attentivement ces instructions avant d'utiliser votre four à micro-ondes et conservez-les soigneusement.

Lire attentivement ces instructions avant d'utiliser votre four à micro-ondes et conservez-les soigneusement.

CONSERVEZ PRECIEUSEMENT CES INSTRUCTIONS

PRÉCAUTIONS AFIN D'ÉVITER UNE ÉVENTUELLE SUREXPOSITION AUX MICRO-ONDES

- (a) N'essayez pas de faire fonctionner ce four avec la porte ouverte car ceci pourrait entraîner une exposition dangereuse à l'énergie micro-ondes. Il est important de ne pas détruire ou essayer de forcer les verrous de sécurité.
- (b) Ne placez pas d'objet entre la façade et la porte du four et ne laissez pas de résidus ou de produits d'entretien s'accumuler sur les surfaces d'étanchéité.
- (c) AVERTISSEMENT: Si la porte ou les joints de porte sont endommagés, le four ne doit pas être utilisé jusqu'à ce qu'il soit réparé par une personne compétente.

INDEX

Si l'appareil n'est pas maintenu dans un bon état de propreté, sa surface peut être dégradée, affecter la durée de vie de l'appareil et entraîner une situation dangereuse.

SPECIFICATIONS

Modèle:	MWE FS20 G WH
Tension nominale:	230 V~ 50 Hz
Puissance d'entrée (micro-ondes) :	1050 W
Puissance de sortie (micro-ondes) :	700 W
Puissance d'entrée (Grill) :	1000 W

INSTRUCTIONS DE SÉCURITÉ IMPORTANTE

AVERTISSEMENT

Pour réduire les risques d'incendie, d'électrocution, de blessures corporelles ou d'exposition excessive aux micro-ondes lors de l'utilisation de votre appareil, suivez-les précautions, incluant les suivantes:

1. Lisez et suivez les instructions spécifiques: «PRÉCAUTIONS POUR ÉVITER UNE EXPOSITION ÉVENTUELLE À UNE DOSE EXCESSIVE DE MICO-ONDES».
2. Cet appareil n'est pas prévu pour être utilisé par les personnes (notamment les enfants) avec des capacités physiques, sensorielles ou mentales réduites ou avec un manque d'expérience ou de connaissances, sans surveillance ou consigne sur l'utilisation de l'appareil par une personne responsable de leur sécurité.
3. Les jeunes enfants doivent être surveillés pour s'assurer qu'ils ne jouent pas avec l'appareil.
4. Si le câble d'alimentation est endommagé, il doit être remplacé par le fabricant, son agent d'entretien ou une personne du même niveau de qualification, afin d'éviter tout danger. (Pour appareil avec accessoire de type Y)
5. **AVERTISSEMENT:** assurez-vous que l'appareil est éteint avant de remplacer la lampe pour éviter tout risque d'électrocution.
6. **AVERTISSEMENT:** il est dangereux pour quiconque autre qu'une personne compétente d'effectuer un entretien ou une réparation opération qui implique le retrait d'un couvercle qui offre une protection contre l'exposition aux micro-ondes.
7. **AVERTISSEMENT:** les liquides et autres aliments ne doivent pas être chauffés dans des récipients fermés car ils sont susceptibles d'exploser.

8. Lorsque vous réchauffez des aliments dans des récipients en plastique ou en papier, surveiller le four en raison du risque d'incendie.
9. Utilisez uniquement des ustensiles adaptés à une utilisation dans des fours à micro-ondes.
10. Si de la fumée se dégage, éteignez ou débranchez l'appareil et gardez la porte fermée afin d'étouffer les flammes.
11. Le réchauffage des boissons par micro-ondes peut entraîner une ébullition retardée, il faut donc faire attention lors de la manipulation du récipient.
12. Le contenu des biberons et des bouchons pour bébé doit être agité ou secoué et la température vérifiée avant consommation, afin d'éviter les brûlures.
13. Les œufs dans leur coquille et les œufs durs entiers ne doivent pas être chauffés au four à micro-ondes car ils peuvent exploser, même après la fin du chauffage par micro-ondes.
14. Le four doit être nettoyé régulièrement et tout dépôt d'aliments doit être retiré.
15. Le fait de ne pas garder le four propre peut entraîner une détérioration de la surface qui pourrait nuire à la durée de vie de l'appareil et peut entraîner des situations dangereuses.
16. L'appareil ne doit pas être installé derrière un porte décorative et ce afin d'éviter toute surchauffe. (Ceci ne s'applique pas aux appareils avec porte décorative.)
17. N'utilisez que la sonde de température recommandée pour ce four (pour les fours pourvus d'une possibilité d'utiliser un sonde de détection de température.)
18. Le four à micro-ondes ne doit pas être placé dans une armoire à moins d'avoir été testé dans une armoire.
19. Le four à micro-ondes doit être utilisé avec porte décorative ouverte. (pour les fours avec une porte décorative.)

20. Cet appareil est destiné à être utilisé dans un usage domestique et des applications similaires telles que:
 - coins cuisine réservés au personnel de magasins, bureaux et autres lieux de travail ;
 - par les clients dans les hôtels, des motels et des autres lieux à caractère résidentiel ;
 - les exploitations agricoles ;
 - hébergements de type chambre d'hôtes.
21. Le four à micro-ondes est prévu pour le réchauffage d'aliments et de boissons. Séchage des aliments ou des vêtements et chauffage des des coussins chauffants, pantoufles, éponges, chiffons humides et autres peuvent entraîner des risques de blessures, d'inflammation ou d'incendie.
22. Des récipients métalliques pour aliments et boissons ne sont pas autorisés pour la cuisson au micro-ondes.
23. L'appareil ne doit pas être nettoyé avec un nettoyeur vapeur.
24. L'appareil est destiné à être utilisé seul.
25. La face arrière des appareils doit être placée contre un mur.

**LIRE ATTENTIVEMENT ET CONSERVER
POUR RÉFÉRENCE ULTÉRIEURE
USAGE DOMESTIQUE UNIQUEMENT
(NON POUR USAGE COMMERCIAL)**

INSTRUCTIONS POUR EVITER LES RISQUES DE DOMMAGES AUX PERSONNES

INSTALLATION DE MISE A LA TERRE

DANGER

Risque de décharge électrique. Toucher certains composants internes peut causer des blessures graves voire la mort. Ne démontez pas et appareil.

AVERTISSEMENT

Risque de décharge électrique. Une utilisation incorrecte de la mise à la terre peut entraîner une décharge électrique. Ne branchez pas l'appareil à une prise tant qu'il n'est pas correctement installé et relié à la terre.

Cet appareil doit être relié à la terre. En cas de court-circuit électrique, la mise à la terre réduit le risque de décharge électrique en procurant un câble d'évacuation au courant électrique. Cet appareil est équipé d'un cordon électrique e pourvu d'une mise à la terre.

La fiche de la prise doit être branchée dans une prise correctement installée et mise à la terre.

Consultez un électricien ou un technicien de SAV qualifié si vous ne comprenez pas totalement les consignes de mise à la terre ou si vous vous demandez si l'appareil est correctement raccordé à la terre. Si une rallonge électrique est nécessaire, utilisez uniquement une rallonge électrique à 3 fils.

1. Un câble d'alimentation court est fourni pour réduire les risques provoqués en trébuchant ou en s'empêtrant dans un cordon plus long.
2. Si un cordon long ou une rallonge électrique sont utilisés:
 - 1) La capacité nominale indiquée du cordon ou de la rallonge doit être au moins égale à la capacité nominale de l'appareil.
 - 2) La rallonge électrique doit être un cordon à 3 fils avec mise à la terre.
 - 3) Le cordon long doit être disposé de manière à ne pas être tendu au-dessus du coin d'une table ou d'un plan de travail, où il peut être tiré par des enfants ou provoquer un trébuchement involontaire.

NETTOYAGE

N'oubliez pas de débrancher l'appareil de l'alimentation électrique.

1. Nettoyez la cavité du four après l'avoir utilisée avec un chiffon légèrement humide.
2. Nettoyer les accessoires de manière habituelle avec de l'eau et du savon.
3. Le cadre de la porte, le joint et les pièces voisines doivent être nettoyés soigneusement avec un chiffon humide lorsqu'ils sont sales.
4. Ne pas utiliser de nettoyants abrasifs ou de grattoirs métalliques pour nettoyer la vitre de la porte du four car ils peuvent rayer la surface, ce qui peut briser le verre.
5. Conseils de nettoyage --- Pour faciliter le nettoyage des parois de la cavité que les aliments cuits peuvent toucher: Placez un demi-citron dans un bol, ajouter 300 ml (1/2 pinte) d'eau et positionnez votre four sur une puissance de 100% pendant 10 minutes. Essuyez le four avec un chiffon doux et sec.

USTENSILES

ATTENTION

Risque de blessures

Il est dangereux pour toute personne non compétente d'effectuer une opération d'entretien ou de réparation nécessitant de retirer les parois extérieures qui protègent de l'exposition à l'énergie micro-ondes.

Consultez les consignes dans la rubrique «Matières que vous pouvez utiliser dans le four micro-ondes ou à éviter dans le four micro-ondes ». Certains ustensiles non métalliques ne peuvent être passés au micro-ondes. En cas de doute, vous pouvez tester l'ustensile en question en suivant la procédure ci-dessous.

Contrôle de l'ustensile :

1. Dans un récipient pour four micro-ondes, versez une tasse d'eau froide (250 ml) et ajoutez l'ustensile en question.
2. Faites chauffer à la puissance maximale pendant 1 minute.
3. Touchez attentivement l'ustensile. Si l'ustensile vide est chaud, ne l'utilisez pas pour cuire au micro-ondes.
4. N'excédez pas un temps de cuisson d'1 minute.

Matières que vous pouvez utiliser dans le four micro-ondes

Ustensiles	Remarques
Plat à gratin	Suivez les instructions du fabricant. L'arrière du plat à gratin doit être placé à au moins 3/16 pouce (5cm) sur le plateau tournant. Un usage incorrect peut entraîner la cassure du plateau tournant.
Vaisselle	Uniquement compatible pour four à micro-ondes. Suivez les instructions du fabricant. N'utilisez pas de vaisselle cassée ou ébréchée.
Bocaux en verre	Enlevez toujours le couvercle. Utilisez uniquement pour chauffer de la nourriture jusqu'à qu'elle soit chaude. La plupart des bocaux en verre ne sont pas résistants à la chaleur et peuvent se casser.
Verrerie	Uniquement de la verrerie pour four résistant à la chaleur. Soyez sûr qu'il n'y a pas de coupe métallique. N'utilisez pas de vaisselle cassée ou ébréchée.
Sacs de cuisson	Suivez les instructions du fabricant. Ne les fermez pas avec une cravate en au four métal. Faites des fentes pour permettre à la vapeur de s'échapper.
Assiettes et gobelets en papier	Utilisez uniquement pour une cuisson courte/chaude. Ne laissez pas le four sans surveillance pendant la cuisson.
Serviettes en papier	Utilisez-les pour couvrir la nourriture pour réchauffer ou pour absorber le gras. Utilisez uniquement sous surveillance pour une cuisson courte.
Papier de parchemin	Utilisez comme une couverture pour empêcher l'éclaboussement ou comme une enveloppe pour une cuisson vapeur.
Plastique	Uniquement compatible au four à micro-ondes. Suivez les instructions du fabricant. Devrait être labélisé "Adapté à une cuisson au four à micro-ondes". Certains récipients en plastique assèchent, comme la nourriture à l'intérieur chauffe. "Les sachets de cuisson" et les sacs hermétiquement fermés doivent être entaillés, percés selon les instructions du paquet.
Film plastique	Uniquement compatible au four à micro-ondes. Sert à couvrir les aliments pendant la cuisson afin de conserver l'humidité. Ne laissez pas le film plastique toucher les aliments.
Thermomètre	Uniquement compatible au four à micro-ondes (viande et thermomètres de confiserie).
Papier sulfurisé	Utilisez comme une couverture pour empêcher l'éclaboussement ou conserver l'humidité.

Matériaux à éviter dans le four à micro-ondes

Ustensiles	Remarques
Plateau d'aluminium	Peut provoquer des étincelles vaisselle sûr de four à micro-ondes Transférez la nourriture dans une.
Carton de nourriture avec poignée en métal	Peut provoquer des étincelles. Transférez la nourriture dans une vaisselle sûr de four à micro-ondes.
Ustensiles en métal ou en métal garnis	Protection métallique de la nourriture contre l'énergie micro-ondes. Les garnitures métalliques peuvent provoquer des étincelles.
Attaches métalliques	Peut s'enflammer dans le four.
Sacs en papier	Peut s'enflammer dans le four.
Mousse en plastique	La mousse en plastique peut faire fondre le liquide à l'intérieur quand il est exposé à une température élevée.
Bois	Le bois s'assèchera quand il est utilisé dans le four à micro-ondes et peut se fendre ou se fissurer.

NOMS DES PIÈCES ET ACCESSOIRES DU FOUR

(En cas de différences entre l'appareil et les images de ce manuel, c'est le produit qui prévaut.)

Retirer le four et tous les matériaux du carton et de la cavité du four.
Votre four est livré avec les accessoires suivants :

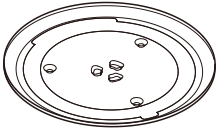

Plateau en Verre



Assemblage de l'anneau du plateau tournant

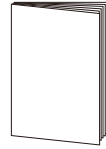

Manuel d'Instructions



Arbre du Plateau Tournant

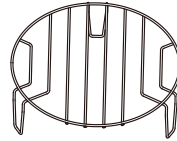

Grille de grill (Ne peut pas être utilisée en mode micro-ondes et doit être placée sur le plateau en verre)

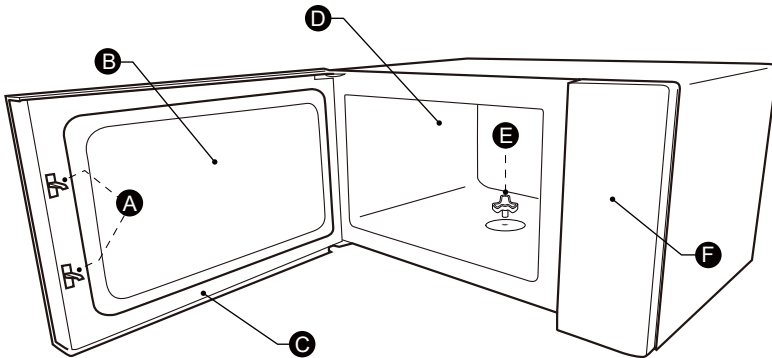

- A) Système de verrouillage de sécurité
- B) Fenêtre d'observation
- C) Assemblage de la porte

- D) Cavité du four
- E) Arbre du plateau tournant
- F) Panneau de commandes

INSTALLATION DU PLATEAU TOURNANT

Nettoyer le compartiment de cuisson et mettre le plateau tournant en place. Pour les nouvelles installations, vérifier que tous les emballages et le ruban d'expédition ont été retirés de l'axe du plateau tournant. Avant d'utiliser l'appareil pour préparer des aliments pour la première fois, il faut mettre le plateau tournant en place correctement. Il faut nettoyer le compartiment de cuisson et les accessoires.

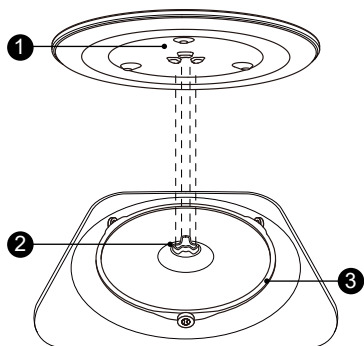

Comment mettre en place le plateau tournant :

1. Placer l'anneau du plateau tournant ③ dans le logement du compartiment de cuisson.
2. Placer le plateau en verre ① sur l'anneau du plateau tournant ③. Placer les lignes courbes en relief au centre du fond du plateau en verre entre les trois rayons de l'arbre. Vérifier que le plateau en verre ① s'engage dans l'arbre du plateau tournant ② au centre du compartiment de cuisson. Les roulettes de l'arbre doivent s'insérer dans l'arête inférieure du plateau tournant.

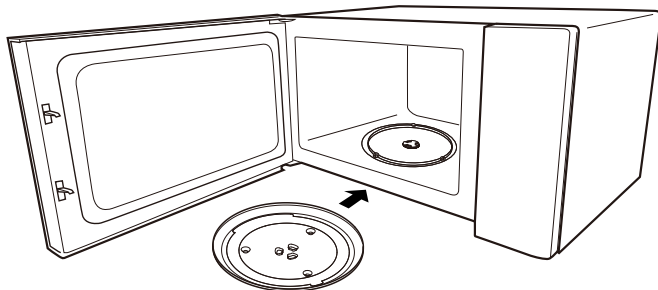

Remarques :

1. Ne jamais utiliser l'appareil sans le plateau tournant. Vérifier qu'il soit correctement imbriqué. Le plateau tournant peut tourner dans le sens des aiguilles d'une montre ou dans le sens inverse.
2. Ne jamais placer le plateau en verre à l'envers. Le plateau en verre ne doit jamais être restreint.
3. Le plateau en verre et l'anneau du plateau tournant doivent toujours être utilisés pendant la cuisson.
4. Tous les aliments et récipients d'aliments sont toujours placés sur le plateau en verre pour la cuisson.
5. Ne jamais limiter le mouvement du plateau tournant.
6. Si le plateau en verre ou l'anneau du plateau tournant se fissure ou se brise, contacter le centre de service agréé le plus proche.

Installation de comptoir

Retirez tous les matériaux d'emballage et les accessoires.

Vérifiez le four pour tous dommages éventuels tels que des bosses ou une porte cassée. Ne pas installer un four endommagé.

Châssis: Retirez le film de protection sur la surface de l'armoire de four à micro-ondes. Ne retirez pas le couvercle du guide d'ondes qui est fixée à la cavité du four pour protéger le magnétron.

Installation

1. Sélectionnez une surface plane offrant un espace suffisant pour l'aération en entrée et en sortie.

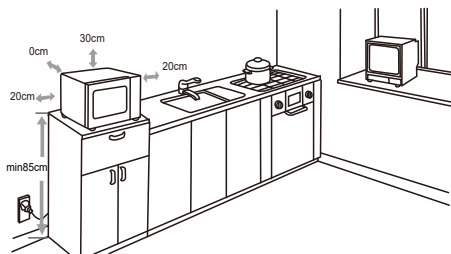

- (1) La hauteur d'installation minimale est de 85 cm.
- (2) L'arrière de l'appareil doit être placé contre un mur. Laissez un dégagement minimum de 30 cm au-dessus du four et un dégagement minimum de 20 cm entre le four et tout mur adjacent.
- (3) Ne retirez pas les pieds du bas du four.
- (4) Bloquer les ouvertures d'entrée et/ou de sortie peut endommager le four.

- (5) Placez le four aussi loin que possible des radios et des télévisions. Le fonctionnement du four à micro-ondes peut perturber la réception de votre radio ou de votre télévision.
2. Branchez votre four dans une prise de courant standard. Assurez-vous que la tension et la fréquence sont identiques à celles indiquées sur l'étiquette de notation.

ATTENTION: Ne pas installer le four au-dessus d'une cuisinière ou de tout autre appareil produisant de la chaleur. Une installation à proximité ou au-dessus d'une source de chaleur pourrait endommager le four et annuler la garantie.

La surface accessible peut être chaude pendant le fonctionnement.



Panneau de contrôle

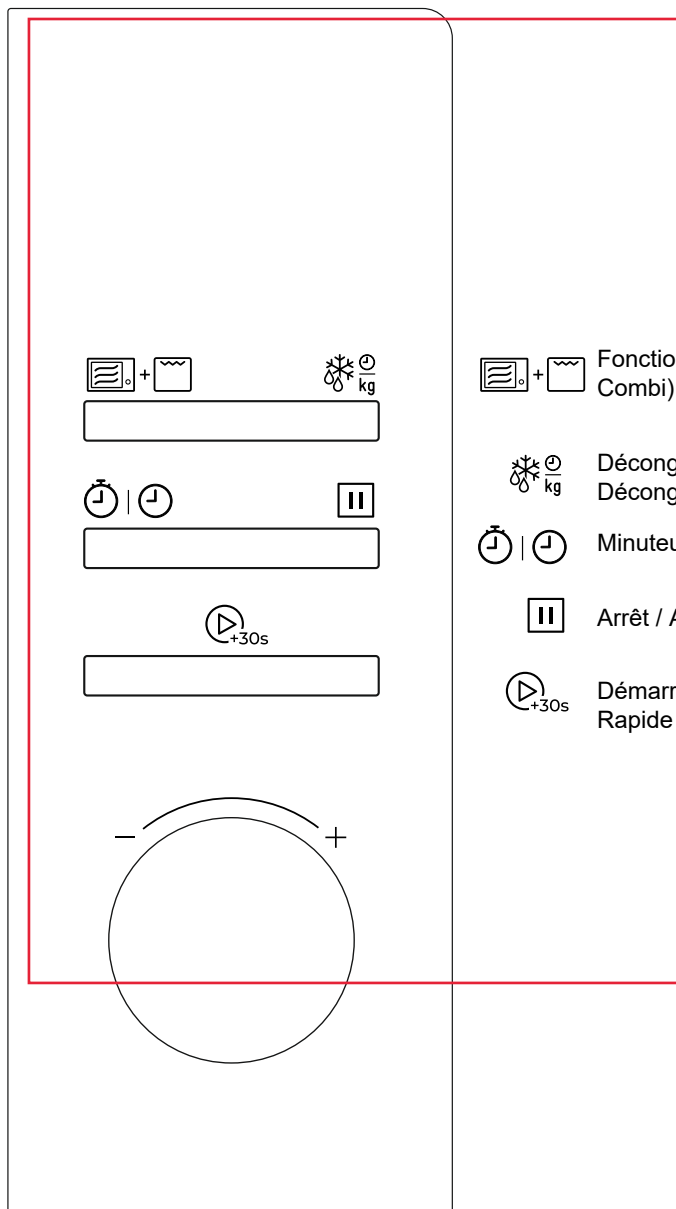

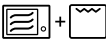
 Fonction (Micro-ondes + Grill + Combi)

 Décongélation par Poids / Décongélation par Temps







 Minuteur / Horloge

 Arrêt / Annuler



 Démarrer / +30 sec. / Cuisson Rapide

OPÉRATION



1. Réglage de l'Horloge

- (1) Appuyez deux fois sur "  |  " et "00:00" s'affichera.
- (2) Tournez le bouton pour régler les heures.
- (3) Appuyez sur "  |  " pour confirmer.
- (4) Tournez le bouton pour régler les minutes.
- (5) Appuyez sur "  |  " pour confirmer. L'horloge est réglée.

Remarques:

- (1) L'horloge affiche l'heure au format 24 heures. Si l'horloge n'est pas réglée, elle ne fonctionnera pas lorsque le courant est allumé.
- (2) Pour réinitialiser l'horloge, veuillez répéter les étapes 1 à 5.
- (3) Après avoir réglé l'horloge, si "  |  " n'est pas pressé ou s'il n'y a aucune opération dans les 1 minute, le réglage est annulé.

2. Réglage du Minuteur de Cuisine







- (1) Appuyez une fois sur "  |  " et "0:00" s'affichera.
- (2) Tournez le bouton pour régler le temps souhaité. La valeur maximale est "95:00".
- (3) Appuyez sur " _{+30s} " pour confirmer. Le minuteur commence à décompter.

Remarque: Le minuteur de cuisine est un minuteur.



3. Cuisson au Micro-ondes

Tableau de Puissance du Micro-ondes

Puissance des micro-ondes	100%	80%	50%	30%	10%
Affichage	P100	P80	P50	P30	P10



- (1) Appuyez une fois sur "  +  " et "P100" s'affichera.
- (2) Appuyez de nouveau sur "  +  " ou tournez le bouton pour régler le niveau de puissance. Il y a 5 niveaux de puissance disponibles.
- (3) Appuyez sur " _{+30s} " pour confirmer.
- (4) Tournez le bouton pour régler le temps de cuisson. La valeur maximale est "95:00".
- (5) Appuyez sur " _{+30s} " pour démarrer la cuisson.

4. Décongélation par Poids

- (1) Appuyez une fois sur "  kg ", l'écran affichera "dEF1".
- (2) Tournez le bouton pour régler le poids des aliments. La plage de poids est de 100 à 2000 g.
- (3) Appuyez sur "  "+30s " pour démarrer la décongélation.

Remarque: Le buzzer retentira pour vous rappeler de retourner les aliments pendant la décongélation. En cas d'absence d'intervention, le four continuera de fonctionner.



5. Décongélation par Temps

- (1) Appuyez deux fois sur "  ", l'écran affichera "dEF2".
- (2) Tournez le bouton pour régler le temps de décongélation souhaité. La valeur maximale est "95:00".
- (3) Appuyez sur "  "+30s " pour démarrer la décongélation.

Remarques:

- (1) Le buzzer retentira pour vous rappeler de retourner les aliments pendant la décongélation. En cas d'absence d'intervention, le four continuera de fonctionner.
- (2) La puissance de décongélation est P30 et ne peut pas être modifiée.

6. Cuisson Rapide

- (1) En mode veille, appuyez sur "  "+30s " pour cuire les aliments à 100% de puissance pendant 30 secondes. Chaque pression sur la même touche augmente de 30 secondes, avec une valeur maximale de "95:00".
- (2) En mode veille, tournez le bouton vers la gauche pour régler le temps de cuisson à 100% de puissance. Continuez à tourner le bouton pour ajuster le temps de cuisson. La valeur maximale est "95:00". Ensuite, appuyez sur "  "+30s " pour démarrer la cuisson.

Remarque: En état de cuisson et de décongélation par temps, chaque pression supplémentaire sur "  "+30s " peut augmenter le temps de cuisson de 30 secondes (sauf pour la décongélation par poids, le menu automatique et la première étape de la cuisson multi-étapes).

7. Cuisson Multi-étapes

Remarques: (1) Deux étapes de cuisson peuvent être programmées en cuisson multi-étapes.

(2) Si vous programmez la fonction de décongélation, elle fonctionnera automatiquement à la première étape.



(3) Le minuteur de cuisine et le menu automatique ne peuvent pas être programmés comme l'une des étapes multi-étapes.

Exemple: Décongeler les aliments pendant 5 minutes puis cuire avec une puissance de micro-ondes de 80% pendant 7 minutes.

(1) Appuyez deux fois sur "  +  ", l'écran affichera "dEF2".

(2) Tournez le bouton pour régler le temps de décongélation souhaité à 5 minutes.

(3) Appuyez une fois sur "  +  " et "P100" s'affichera.

(4) Appuyez de nouveau sur "  +  " ou tournez le bouton pour régler le niveau de puissance à P80.



(5) Appuyez sur "  +30s " pour confirmer.

(6) Tournez le bouton pour régler le temps de cuisson à 7 minutes.

(7) Appuyez sur "  +30s " pour démarrer la cuisson.

8. Cuisson Grill et Combinée

(1) Appuyez une fois sur "  +  " et "P100" s'affichera.

(2) Appuyez de nouveau sur "  +  " ou tournez le bouton jusqu'à ce que "G-1", "C-1" et "C-2" s'affichent successivement.

(3) Appuyez sur "  +30s " pour confirmer.

(4) Tournez le bouton pour régler le temps de cuisson. La valeur maximale est "95:00".

(5) Appuyez sur "  +30s " pour démarrer la cuisson.

Remarque: Le buzzer retentira pour vous rappeler de retourner les aliments pendant la cuisson au grill. En cas d'absence d'intervention, le four continuera de fonctionner.

Tableau de Cuisson Combinée

Fonction	Affichage	Puissance du Micro-ondes	Puissance du Grill
Combi. 1	C-1	55%	45%
Combi. 2	C-2	36%	64%

9. Menu Automatique



- (1) Tournez le bouton vers la droite et "A-1" s'affichera.
- (2) Continuez à tourner le bouton pour choisir le menu dont vous avez besoin. Les 8 menus automatiques sont disponibles.
- (3) Appuyez sur "  " pour confirmer.
- (4) Tournez le bouton pour régler le poids des aliments.
- (5) Appuyez sur "  " pour démarrer la cuisson.



Tableau des Menus Automatiques

Menu	Poids	Affichage	Puissance
A-1 Réchauffage automatique	200g	200	P100
	400g	400	
	600g	600	
A-2 Légumes	300g	300	P100
	400g	400	
A-3 Poisson	250g	250	P80
	350g	350	
	450g	450	
A-4 Viande	250g	250	P100
	350g	350	
	450g	450	
A-5 Pâtes	50g (avec 450g d'eau froide)	50	P80
	100g (avec 800g d'eau froide)	100	
A-6 Pomme de terre	200g	200	P100
	400g	400	
	600g	600	
A-7 Pizza	200g	200	P100
	400g	400	
A-8 Soupe	200ml	200	P100
	400ml	400	

10. Fonction de verrouillage pour enfants

Vous pouvez utiliser cette fonction pour empêcher les enfants d'allumer accidentellement le four.



Pour activer le verrouillage:



En mode veille, maintenez enfoncé " " pendant trois secondes. Un long bip retentit et " " s'affiche.

Pour désactiver le verrouillage:

En état verrouillé, maintenez enfoncé " " pendant trois secondes. Un long bip retentit.

11. Fonction d'interrogation

(1) Si l'horloge a été réglée, l'heure actuelle s'affichera pendant trois secondes en appuyant sur " |  " en état de cuisson.

(2) En mode micro-ondes, grill, ou cuisson combinée, appuyez sur " +  " pour consulter le niveau de puissance ou le mode de cuisson. L'information s'affichera pendant trois secondes.

Dépannage

Normal	
Four à micro-ondes interférant la réception TV	La réception radio et TV peuvent être interférées pendant l'utilisation du four à micro-ondes. Il est similaire à l'interférence des petits appareils électriques, comme le mixeur, l'aspirateur, et le ventilateur électrique. C'est normal.
Lumière du four terne	En faible puissance de cuisson du four, la lumière du four peut devenir terne. C'est normal.
Accumulation de la vapeur sur la porte, air chaud de la ventilation	En cuisson, de la vapeur peut provenir de la nourriture. La majeure partie sortira par les orifices. Mais certaines vapeurs peuvent s'accumuler dans d'autres endroits comme la porte. C'est normal.
Accumulation de la vapeur sur la porte, air chaud de la ventilation	Il est interdit de faire fonctionner le four sans nourriture à l'intérieur. C'est dangereux.

Panne	Cause possible	Remède
Le four ne peut pas être démarré.	(1) Le câble d'alimentation n'est pas fermement branché .	Débranchez. Rebranchez après 10 secondes.
	(2) Fusible soufflant ou disjoncteur fonctionne.	Remplacez le fusible ou réinitialisez le disjoncteur (réparé par un personnel qualifié de notre compagnie)
	(3) Problème avec la prise de courant	Testez la prise de courant avec d'autres matériels électriques.
Le four ne produit pas de chaleur.	(4) La porte n'est pas bien fermée.	Fermez bien la porte.

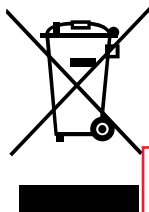

Conformément à la directive Déchets d'équipements électriques et électroniques (DEEE), les DEEE doivent être collectés et traités séparément. Si à l'avenir vous souhaitez vous débarrasser de ce produit, veuillez ne PAS le jeter avec les déchets domestiques. Veuillez envoyer ce produit aux points de collecte DEEE disponibles.



Points de collecte sur www.quefairemesdechets.fr
Privilégiez la réparation ou le don de votre appareil !

Mikrowelle

BEDIENUNGSANLEITUNG

Modell: MWE FS20 G WH

Bitte lesen Sie die Bedienungsanleitung vor dem Gebrauch des Geräts sorgfältig durch und bewahren Sie diese für ein zukünftiges Nachschlagen gut auf.

Sofern Sie die Bedienungsanleitung befolgen, wird Ihnen diese Mikrowelle über viele Jahre hinweg gute Dienste leisten.

BEWAHREN SIE DIESE BEDIENUNGSANLEITUNG GUT AUF

SICHERHEITSVORKEHRUNGEN ZUM SCHUTZ VOR ÜBERMÄSSIGER MIKROWELLENSTRAHLUNG

- (a) Verwenden Sie die Mikrowelle nicht mit geöffneter Tür, da Sie sich anderenfalls gefährlicher Mikrowellenstrahlung aussetzen. Die Sicherheitsvorrichtungen dürfen nicht zerstört oder modifiziert werden.
- (b) Legen Sie keine Gegenstände zwischen die Tür und die Vorderseite des Geräts. Sorgen Sie dafür, dass sich weder Schmutz noch Reinigungsmittelrückstände auf den Dichtungen ansammeln.
- (c) **WARNUNG:** Falls die Tür oder Türdichtungen beschädigt sind, darf das Gerät erst wieder verwendet werden, wenn es von einer qualifizierten Fachkraft repariert wurde.

ERGÄNZUNG

Wird das Gerät nicht in einem guten und sauberen Zustand gehalten, könnten die Oberfläche zerstört und dadurch die Lebensdauer des Geräts beeinträchtigt und Gefahrensituationen verursacht werden.

TECHNISCHE DATEN

Modell:	MWE FS20 G WH
Nennspannung:	230 V~ 50 Hz
Nenneingangsleistung (Mikrowelle):	1050 W
Nennausgangsleistung (Mikrowelle):	700 W
Nenneingangsleistung (Grill):	1000 W

WICHTIGE SICHERHEITSHINWEISE

WARNUNG

Um das Risiko eines Brands, elektrischen Schlags, einer Verletzung oder Exposition gegen übermäßige Mikrowellenstrahlung zu verringern, müssen die folgenden grundlegenden Vorsichtsmaßnahmen beachtet werden:

1. Lesen und befolgen Sie die folgenden Punkte für:
„VORKEHRUNGEN ZUR VERMEIDUNG EINER MÖGLICHEN EXPOSITION GEGENÜBER ÜBERMÄSSIGER MIKROWELLENSTRAHLUNG“.
2. Dieses Gerät ist geeignet für den Gebrauch durch Kinder ab 8 Jahren sowie für Personen mit eingeschränkten körperlichen, sensorischen oder geistigen Fähigkeiten oder ohne Erfahrung und Wissen, sofern sie beaufsichtigt oder hinsichtlich der sicheren Nutzung unterwiesen werden und die damit einhergehenden Gefahren verstehen. Kinder dürfen nicht mit dem Gerät spielen. Reinigungsarbeiten und Benutzerwartungen dürfen von Kindern nur unter Aufsicht durchgeführt werden.
3. Halten Sie das Gerät und das Kabel außerhalb der Reichweite von Kindern unter 8 Jahren.
4. Falls das Netzkabel beschädigt ist, muss es vom Hersteller, seinem Kundendienst oder einer ähnlich qualifizierten Person ausgetauscht werden, um eine Gefährdung zu vermeiden.
5. **WARNUNG:** Stellen Sie sicher, dass das Gerät vor dem Auswechseln der Lampe ausgeschaltet ist, um die Gefahr eines Stromschlags zu vermeiden.
6. **WARNUNG:** Es besteht eine Gefahrensituation, falls Wartungs- oder Reparaturarbeiten von nicht fachkundigen Personen durchgeführt werden, bei denen eine Abdeckung entfernt werden muss, die vor der Exposition von Mikrowellenstrahlung schützt.

7. **WARNUNG:** Flüssigkeiten und andere Lebensmittel dürfen nicht in verschlossenen Behältern erhitzt werden, da diese explodieren könnten.
8. Wenn Sie Speisen in Plastik- oder Papierbehältern aufwärmen, dürfen Sie die Mikrowelle nicht aus den Augen lassen, da Brandgefahr besteht.
9. Verwenden Sie nur mikrowellengeeignetes Zubehör.
10. Wenn Rauch austritt, schalten Sie das Gerät aus oder ziehen Sie den Stecker aus der Steckdose. Lassen Sie die Tür geschlossen, um mögliche Flammen zu ersticken.
11. Flüssigkeiten, die in der Mikrowelle erhitzt werden, können verzögert überkochen. Deren Behälter müssen daher besonders vorsichtig gehandhabt werden.
12. Inhalte in Babyflaschen und Kindernahrung in Gläsern müssen umgerührt oder geschüttelt werden. Überprüfen Sie vor dem Füttern die Temperatur, um Verbrennungen zu vermeiden.
13. Ungeschälte sowie ganze hart gekochte Eier dürfen nicht in Mikrowellen erhitzt werden; sie könnten explodieren, auch wenn der Kochvorgang bereits abgeschlossen ist.
14. Reinigen Sie die Mikrowelle regelmäßig und entfernen Sie Essensrückstände.
15. Wird das Gerät nicht in einem guten und sauberen Zustand gehalten, könnten die Oberfläche zerstört und dadurch die Lebensdauer des Geräts beeinträchtigt und Gefahrensituationen verursacht werden.
16. Um Überhitzung zu vermeiden, darf das Gerät nicht hinter einer Dekotür installiert werden. (Dies gilt nicht für Geräte mit Dekotür.)
17. Verwenden Sie nur den mit diesem Gerät mitgelieferten Temperaturfühler (nur bei Geräten mit einer Vorrichtung zum Gebrauch eines Temperaturmessfühlers).
18. Die Mikrowelle darf nicht in einem Schrank platziert werden, es sei denn, sie wurde in einem Schrank getestet.

19. Während des Betriebs der Mikrowelle muss die Dekotür geöffnet werden (nur bei Mikrowellen mit Dekotür).
20. Dieses Gerät ist für den Gebrauch in Haushalten und ähnliche Anwendungen bestimmt, wie z.B.:
 - Mitarbeiterküchen in Geschäften, Büros und anderen Arbeitsumgebungen;
 - Kunden in Hotels, Motels und anderen Unterkünften;
 - Gutshäuser;
 - Frühstückspensionen.
21. Die Mikrowelle ist zum Erhitzen von Speisen und Getränken vorgesehen. Das Trocknen von Lebensmitteln oder Kleidung, sowie das Erhitzen von Wärmepads, Schuhen, Schwämmen, feuchter Kleidung oder ähnlichem können Verletzungen oder Feuer verursachen.
22. Lebensmittel- und Getränkebehälter aus Metall dürfen nicht zum Kochen in der Mikrowelle verwendet werden.
23. Das Gerät darf nicht mit einem Dampfreiniger gereinigt werden.
24. Das Gerät muss freistehend verwendet werden.
25. Die Hinterseite des Geräts muss an einer Wand stehen.

**DIE ANWEISUNGEN SORGFÄLTIG LESEN UND FÜR
DAS SPÄTERE NACHSCHLAGEN AUFBEWAHREN
NUR FÜR DEN HAUSGEBRAUCH BESTIMMT
(NICHT FÜR DEN GEWERBLICHEN GEBRAUCH)**

ZUR REDUZIERUNG VON VERLETZUNGSRISIKEN FÜR PERSONEN AUFGRUND DER ERDUNGSINSTALLATION GEFAHR

Stromschlaggefahr:

Das Berühren einiger interner Komponenten kann zu schweren Verletzungen oder gar zum Tode führen. Nehmen Sie das Gerät nicht auseinander.

WARNUNG

Stromschlaggefahr

Bei unsachgemäßer Erdung besteht Stromschlaggefahr. Schließen Sie das Gerät erst dann an das Netz an, wenn es ordnungsgemäß installiert und geerdet wurde.

Dieses Gerät muss geerdet werden. Im Falle eines Kurzschlusses reduziert der Schutzleiter die Gefahr eines Stromschlags, indem er für den Stromfluss einen Fluchtweg bietet. Das Netzkabel dieses Geräts verfügt über einen Schutzleiter mit Erdungsvorrichtung am Stecker.

Schließen Sie den Netzstecker an eine ordnungsgemäß installierte und geerdete Steckdose an.

Wenden Sie sich an einen qualifizierten Elektriker oder Techniker, falls Sie die Anleitungen zur Erdung nicht verstehen oder falls Sie Zweifel haben, ob Ihr Gerät ordnungsgemäß geerdet ist. Falls Sie eine

Verlängerungsschnur verwenden, dann nur ein 3-adriges Verlängerungskabel mit 3-zackigem Stecker. Die auf dem Netzkabel gekennzeichneten

Leistungsangaben müssen den elektrischen

Leistungsangaben des Geräts entsprechen oder höher sein.

1. Das Gerät verfügt über ein kurzes Netzkabel, um ein Verheddern des Kabels oder Stolpergefahren für Personen zu vermeiden.

2. Beachten Sie beim Gebrauch eines längeren Netzkabels oder Verlängerungskabels folgendes:
 - 1) Die Leistungsangaben auf dem Kabel oder Verlängerungskabel müssen mindestens genauso hoch sein wie die Leistungsangaben auf dem Gerät.
 - 2) Bei der Verlängerungsschnur muss es sich um ein 3-adriges, geerdetes Kabel handeln.
 - 3) Längere Kabel müssen so verlegt werden, dass niemand versehentlich darüber stolpern kann und dass sie nicht über Arbeitsflächen oder Tischkanten herunterhängen, wo Kinder daran ziehen könnten.

REINIGUNG

Trennen Sie das Gerät vom Stromnetz.

1. Reinigen Sie den Garraum des Geräts nach dem Gebrauch mit einem leicht angefeuchteten Lappen.
2. Reinigen Sie das Zubehör normal in Spülwasser.
3. Wenn der Rahmen und die Dichtungen der Tür und angrenzende Teile schmutzig sind, müssen sie mit einem feuchten Lappen gereinigt werden.
4. Verwenden Sie keine aggressiven Scheuermittel oder scharfe Metallkratzer zum Reinigen der Glastür, da anderenfalls die Oberfläche beschädigt und daraus resultierend das Glas zerbrechen könnte.
5. Tipps für die Reinigung---Zum Entfernen von Essensrückständen an den Wänden des Garraums: Legen Sie eine halbe Zitrone in eine Schüssel, fügen Sie 300 ml (1/2 Pint) Wasser hinzu und erhitzen Sie das Gemisch 10 Minuten lang bei 100% Mikrowellenleistung. Wischen Sie das Gerät danach mit einem weichen, trockenen Lappen aus.

KÜCHENGESCHIRR

VORSICHT

Verletzungsgefahr:

Es besteht eine Gefahrensituation, falls Wartungs- oder Reparaturarbeiten von nicht fachkundigen Personen durchgeführt werden, bei denen eine Abdeckung entfernt werden muss, die vor der Exposition von Mikrowellenstrahlung schützt.

Beachten Sie die Hinweise unter „Verwendbare Materialien in der Mikrowelle“ bzw. „Nicht verwendbare Materialien in der Mikrowelle“.

Es kann möglicherweise sein, dass bestimmtes nichtmetallisches Kochgeschirr nicht zur sicheren Verwendung in der Mikrowelle geeignet ist. Im Zweifelsfall können Sie das betreffende Kochgeschirr nach dem folgenden Verfahren testen.

Kochgeschirr-Test:

1. Füllen Sie ein mikrowellengeeignetes Gefäß mit 1 Tasse kaltem Wasser (250 ml) und stellen Sie das entsprechendem Kochgeschirr hinein.
2. Betreiben Sie die Mikrowelle für 1 Minute lang bei maximaler Leistung.
3. Berühren Sie das Gerät vorsichtig. Falls das leere Kochgeschirr warm ist, darf es nicht für Garvorgänge in der Mikrowelle verwendet werden.
4. Überschreiten Sie nicht die Garzeit von 1 Minute.

Verwendbare Materialien in der Mikrowelle

Kochgeschirr	Anmerkungen
Bräunungsschale	Beachten Sie die Anweisungen des Herstellers. Der Boden der Bräunungsschale muss sich mindestens 5 mm (3/16 Zoll) über dem Drehteller befinden. Bei unsachgemäßer Verwendung kann der Drehteller brechen.
Essgeschirr	Nur mikrowellengeeignetes Geschirr verwenden. Beachten Sie die Anweisungen des Herstellers. Verwenden Sie kein gesprungenes Geschirr oder Geschirr mit Absplitterungen.
Glasgefäße	Deckel immer abnehmen. Nur zum Anwärmen von Speisen verwenden. Die meisten Glasgefäße sind nicht hitzebeständig und können zerbrechen.
Glaswaren	Nur hitzebeständiges Ofen-Glasgeschirr verwenden. Achten Sie darauf, dass keine Metallteile vorhanden sind. Verwenden Sie kein gesprungenes Geschirr oder Geschirr mit Absplitterungen.
Bratschläuche	Beachten Sie die Anweisungen des Herstellers. Nicht mit Metallbändern verschließen. Schlitze einfügen, damit der Dampf entweichen kann.
Pappteller und -becher	Nur zum kurzfristigen Garen/Aufwärmen verwenden. Lassen Sie die Mikrowelle während des Garens nicht unbeaufsichtigt.
Papierhandtücher	Zum Abdecken von Speisen für das Aufwärmen und zum Aufsaugen von Fett verwenden. Nur unter Aufsicht für kurzzeitiges Garen verwenden.
Backpapier	Zum Abdecken, um Spritzer zu vermeiden oder zum Einwickeln beim Dampfgaren.
Kunststoffe	Nur mikrowellengeeignetes Geschirr verwenden. Befolgen Sie die Anweisungen des Herstellers. Sollte als „mikrowellengeeignet“ beschriftet sein. Einige Kunststoffbehälter werden weich, wenn die Lebensmittel darin heiß werden. „Kochbeutel“ und fest verschlossene Kunststoffbeutel sollten entsprechend den Anweisungen auf der Verpackung aufgeschlitzt, durchstochen oder belüftet werden.
Frischhaltefolie	Nur mikrowellengeeignetes Geschirr verwenden. Zum Abdecken von Lebensmitteln während des Garvorgangs zum Beibehalten der Feuchtigkeit verwenden. Vergewissern Sie sich, dass die Frischhaltefolie die Lebensmittel nicht berührt.
Thermometer	Nur mikrowellengeeignete (Fleisch- und Zuckerthermometer) verwenden.
Wachspapier	Zum Abdecken, um Spritzer zu vermeiden und zur Beibehaltung der Feuchtigkeit.

Nicht verwendbare Materialien in der Mikrowelle

Kochgeschirr	Anmerkungen
Aluminiumschale	Kann zu Funkenbildung führen. Speisen in eine mikrowellengeeignete Schale umfüllen.
Lebensmittelkarton mit Metallgriff	Kann zu Funkenbildung führen. Speisen in eine mikrowellengeeignete Schale umfüllen.
Kochgeschirr aus Metall oder metallverziertes Kochgeschirr	Metall schirmt die Lebensmittel vor der Mikrowellenstrahlung ab. Metallverzierungen können Funkenbildung verursachen.
Mit Metall versehene Bänder	Kann zu Funkenbildung und zu einem Brand in der Mikrowelle führen.
Papiertüten	Können einen Brand in der Mikrowelle verursachen.
Schaumstoff	Schaumstoff kann schmelzen bzw. Flüssigkeiten der Lebensmittel kontaminieren, wenn es hohen Temperaturen ausgesetzt wird.
Holz	Holz trocknet bei Verwendung in der Mikrowelle aus und kann splintern oder brechen.

Geräteteile und zubehör

(Im Falle von Unterschieden zwischen dem Gerät und den Bildern in diesem Handbuch ist das Produkt maßgebend.)

Entfernen Sie den Ofen und alle Materialien aus dem Karton und dem Garraum. Ihre Mikrowelle wird mit folgendem Zubehör geliefert:

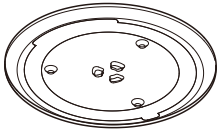

Glasteller



Drehring



Bedienungsanleitung



Antrieb des Drehtellers

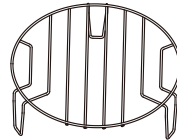

Grillgestell (kann nicht im Mikrowellenbetrieb verwendet werden und muss auf das Glastablett gelegt werden)

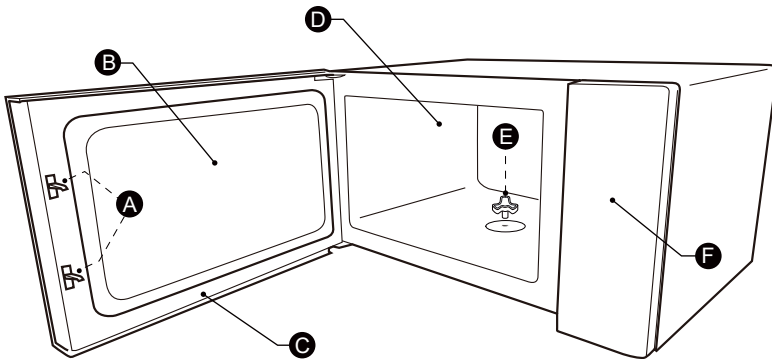

- A) Sicherheitsverriegelungs-system
- B) Beobachtungsfenster
- C) Türmontage

- D) Ofenhöhle
- E) Antrieb des Drehtellers
- F) Bedienfeld

DREHTELLERS INSTALLATION

Reinigen Sie den Garraum und installieren Sie den Drehteller entsprechend. Entfernen Sie vor der erstmaligen Installation alle Verpackungsmaterialien und Klebebänder von der Drehwelle. Achten Sie darauf, den Drehteller richtig zu positionieren. Reinigen Sie den Garraum und das gesamte Zubehör.

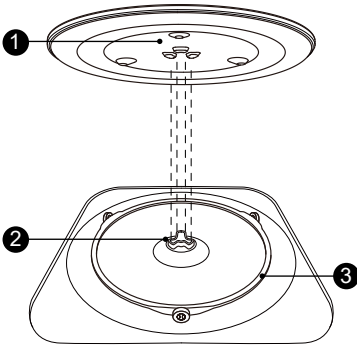

So setzen Sie den Drehtellers an der richtigen Stelle:

1. Legen Sie den Drehring ③ des Drehtellers in die Vertiefung im Innenraum des Geräts.
2. Setzen Sie den Glasteller ① auf den Drehring ③. Positionieren Sie die Vorsprünge unten in der Mitte des Glastellers auf der Welle. Stellen Sie sicher, dass der Glasteller ① auf der Antrieb des Drehtellers ② in der Mitte des Garraums einrastet. Die Rollen der Welle sollten in der Vertiefung an der Unterseite des Glastellers sitzen.

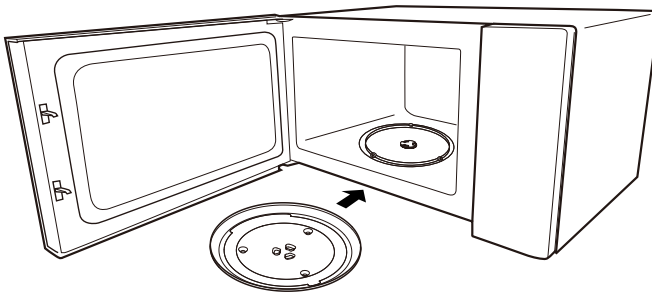

Hinweis:

1. Verwenden Sie das Gerät niemals ohne Drehteller. Vergewissern Sie sich, dass der Drehteller immer sicher installiert ist. Der Glasteller kann sich im und entgegen dem Uhrzeigersinn drehen.
2. Drehen Sie den Glasteller nicht um; der Glasteller darf nicht blockiert werden.
3. Sowohl Glasteller als auch Drehtellerring und Welle müssen während des Kochvorgangs verwendet werden.
4. Einige Speisen bzw. Behälter werden zum Kochen immer auf die Mitte des Glastellers gestellt.
5. Die Bewegung des Glastellers darf nicht eingeschränkt sein.
6. Falls der Glasteller oder der Drehring bzw. die Welle kaputt gehen, wenden Sie sich bitte an einen autorisierten Kundendienst.

Installation auf Arbeitsflächen

Entfernen Sie das gesamte Verpackungsmaterial und Zubehör. Untersuchen Sie die Mikrowelle auf mögliche Schäden wie Dellen oder Risse in der Tür. Im Schadensfall darf die Mikrowelle nicht installiert werden.

Gehäuse: Entfernen Sie Schutzfolien auf der Gehäuseoberfläche des Geräts. Entfernen Sie nicht die hellbraune Glimmer scheibe im Inneren der Mikrowelle. Diese schützt das Magneton.

Installation

1. Wählen Sie einen ebenen Untergrund mit genügend Platz für die Lufteingänge und/oder Luftausgänge.

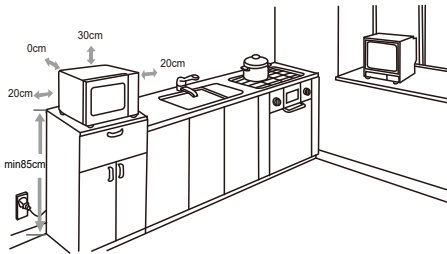

- (1) Die Mindesthöhe für die Installation beträgt 85 cm.
- (2) Die Hinterseite des Geräts muss an einer Wand stehen. Halten Sie über dem Gerät einen Sicherheitsabstand von mindestens 30 cm ein. Lassen Sie zwischen der Mikrowelle und angrenzenden Wänden mindestens 20 cm Platz.
- (3) Entfernen Sie nicht die Standfüße an der Unterseite des Geräts.
- (4) Bei einer Blockierung der Lufteingänge und/oder Luftausgänge kann das Gerät beschädigt werden.

(5) Stellen Sie das Gerät so weit weg wie möglich von Radios und Fernsehern auf. Der Betrieb der Mikrowelle kann den Empfang Ihres Radios oder Fernsehers stören.

2. Schließen Sie Ihre Mikrowelle an eine herkömmliche Steckdose an. Vergewissern Sie sich, dass die Spannung und die Frequenz mit den Angaben auf dem Typenschild übereinstimmen.

WARNUNG: Installieren Sie die Mikrowelle nicht über einem Küchenherd oder anderen wärmeerzeugenden Geräten. Wird die Mikrowelle in der Nähe oder oberhalb eines wärmeerzeugenden Geräts installiert, könnte die Mikrowelle beschädigt werden. Die Garantie wird in solch einem Fall nichtig.

Zugängliche Oberflächen können während des Betriebs heiß werden.



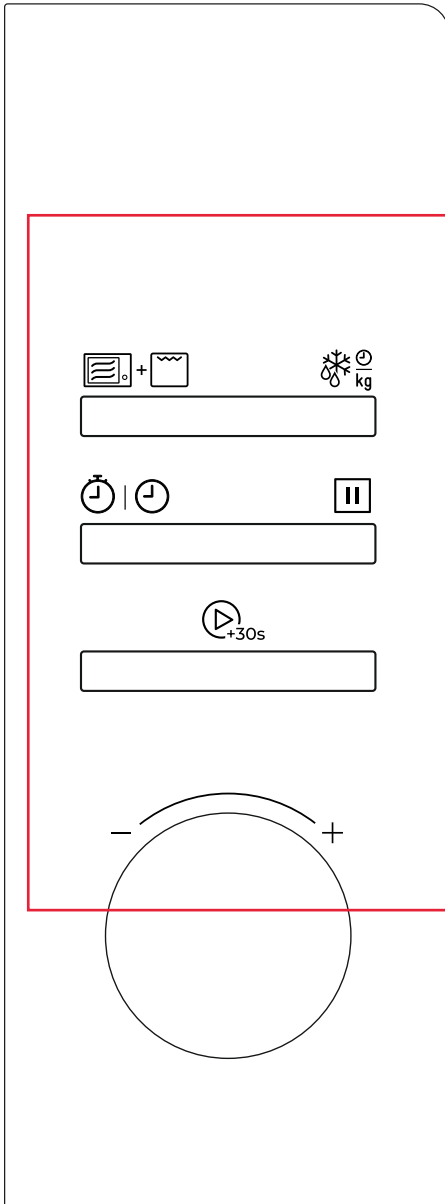

Bedienfeld

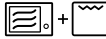

 Funktion
(Mikrowelle+Grill+Kombi)

 Auftauen nach Gewicht/Auftauen
nach Zeit







 Timer/Uhr

 Stoppen/Abbrechen



 Start/+30Sek./Schnelles Kochen

BETRIEB



1. Einstellen der Uhr

- (1) Drücken Sie zweimal „ | “ und dann wird „00:00“ angezeigt.
- (2) Drehen Sie den Knopf, um die Stunden einzustellen.
- (3) Drücken Sie „ | “, um zu bestätigen.
- (4) Drehen Sie den Knopf, um die Minuten einzustellen.
- (5) Drücken Sie „ | “, um zu bestätigen. Die Uhr ist eingestellt.

Hinweise:

- (1) Die Uhr zeigt die Zeit im 24-Stunden-Format an. Wenn die Uhr nicht eingestellt ist, funktioniert sie nicht bei eingeschalteter Stromversorgung.
- (2) Um die Uhr zurückzusetzen, wiederholen Sie bitte Schritt 1 bis Schritt 5.
- (3) Nach dem Einstellen der Uhr wird die Einstellung ungültig, wenn „ | “ nicht gedrückt wird oder innerhalb von 1 Minute keine Operation erfolgt.

2. Einstellen des Küchentimers







- (1) Drücken Sie einmal „ | “ und dann wird „0:00“ angezeigt.
- (2) Drehen Sie den Knopf, um die gewünschte Zeit einzustellen. Der maximale Zeitwert beträgt „95:00“.
- (3) Drücken Sie „“_{+30s}“, um zu bestätigen. Der Timer beginnt mit der Countdown-Zählung.

Hinweis: Der Küchentimer ist ein Timer.



3. Mikrowellenkochen

Mikrowellenleistungs-Tabelle

Mikrowellenleistung	100%	80%	50%	30%	10%
Anzeige	P100	P80	P50	P30	P10



- (1) Drücken Sie einmal „ + “ und dann wird „P100“ angezeigt.
- (2) Drücken Sie „ + “ wiederholt oder drehen Sie den Knopf, um die Leistungsstufe einzustellen. Es stehen 5 Leistungsstufen zur Verfügung.
- (3) Drücken Sie „“_{+30s}“, um zu bestätigen.
- (4) Drehen Sie den Knopf, um die Kochzeit einzustellen. Der maximale Zeitwert beträgt „95:00“.
- (5) Drücken Sie „“_{+30s}“, um mit dem Kochen zu beginnen.

4. Auftauen nach Gewicht

- (1) Drücken Sie einmal „  kg “, dann wird „dEF1“ angezeigt.
- (2) Drehen Sie den Knopf, um das Gewicht des Lebensmittels einzustellen. Der Bereich des Gewichts liegt zwischen 100 und 2000 g.
- (3) Drücken Sie „  “, um mit dem Auftauen zu beginnen.

Hinweis: Der Summer wird Sie daran erinnern, das Essen während des Auftauens umzudrehen. Wenn keine Operation erfolgt, wird der Ofen weiterarbeiten.



5. Auftauen nach Zeit

- (1) Drücken Sie zweimal „  kg “, dann wird „dEF2“ angezeigt.
- (2) Drehen Sie den Knopf, um die gewünschte Auftauzeit einzustellen. Der maximale Zeitwert beträgt „95:00“.
- (3) Drücken Sie „  “, um mit dem Auftauen zu beginnen.

Hinweise:

- (1) Der Summer wird Sie daran erinnern, das Essen während des Auftauens umzudrehen. Wenn keine Operation erfolgt, wird der Ofen weiterarbeiten.
- (2) Die Auftauleistung beträgt P30 und kann nicht geändert werden.

6. Schnellkochen

- (1) Im Bereitschaftsmodus drücken Sie „  “, um das Essen mit 100 % Leistung für 30 Sekunden zu kochen. Jedes weitere Drücken auf die gleiche Taste erhöht die Zeit um 30 Sekunden, der maximale Zeitwert beträgt „95:00“.
- (2) Im Bereitschaftsmodus drehen Sie den Knopf nach links, um eine Kochzeit mit 100 % Leistung einzustellen. Drehen Sie weiter am Knopf, um die Kochzeit anzupassen. Der maximale Zeitwert beträgt „95:00“. Drücken Sie dann „  “, um mit dem Kochen zu beginnen.







Hinweis: Im Koch- und Auftau-Modus nach Zeit erhöht jedes weitere Drücken auf „  “ die Kochzeit um 30 Sekunden (außer beim Auftauen nach Gewicht, Automatikmenü und der ersten Stufe des Mehrstufen-Kochens).

7. Mehrstufen-Kochen







Hinweise:(1) Im Mehrstufen-Kochen können zwei Kochstufen eingestellt werden.

- (2) Wenn Sie die Auftau-Funktion einstellen, wird diese automatisch in der ersten Stufe aktiviert.
- (3) Der Küchentimer und das Automatikmenü können nicht als eine der Mehrstufen eingestellt werden.

Beispiel: Lebensmittel 5 Minuten auftauen und dann 7 Minuten mit 80 % Mikrowellenleistung kochen.

- (1) Drücken Sie zweimal „“ , dann wird „dEF2“ angezeigt.
- (2) Drehen Sie den Knopf, um die gewünschte Auftauzeit auf 5 Minuten einzustellen.
- (3) Drücken Sie einmal „+“ und dann wird „P100“ angezeigt.
- (4) Drücken Sie „+“ erneut oder drehen Sie den Knopf, um die Leistungsstufe auf P80 einzustellen.
- (5) Drücken Sie „+30s“ , um zu bestätigen.
- (6) Drehen Sie den Knopf, um die Kochzeit auf 7 Minuten einzustellen.
- (7) Drücken Sie „+30s“ , um mit dem Kochen zu beginnen.

8. Grill- und Kombinationskochen



- (1) Drücken Sie einmal „+“ , dann wird „P100“ angezeigt.
- (2) Drücken Sie „+“ wiederholt oder drehen Sie den Knopf, bis „G-1“ , „C-1“ und „C-2“ nacheinander angezeigt werden.
- (3) Drücken Sie „+30s“ , um zu bestätigen.
- (4) Drehen Sie den Knopf, um die Kochzeit einzustellen. Der maximale Zeitwert beträgt „95:00“.
- (5) Drücken Sie „+30s“ , um mit dem Kochen zu beginnen.

Hinweis: Der Summer wird Sie daran erinnern, das Essen während des Grillens umzudrehen. Wenn keine Operation erfolgt, wird der Ofen weiterarbeiten.

Kombinationskochen-Tabelle

Funktion	Anzeige	Mikrowellenleistung	Grilleistung
Kombi. 1	C-1	55%	45%
Kombi. 2	C-2	36%	64%

9. Auto-Menu

- (1) Drehen Sie den Knopf nach rechts, dann wird „A-1“ angezeigt.
- (2) Drehen Sie den Knopf weiter, um das benötigte Menü auszuwählen. Es stehen 8 Auto-Menüs zur Verfügung.
- (3) Drücken Sie „“, um zu bestätigen.
- (4) Drehen Sie den Knopf, um das Gewicht des Lebensmittels einzustellen.
- (5) Drücken Sie „“, um mit dem Kochen zu beginnen.



Auto-Menü Tabelle

Menü	Gewicht	Anzeige	Leistung
A-1 Automatische Aufwärmen	200g	200	P100
	400g	400	
	600g	600	
A-2 Gemüse	300g	300	P100
	400g	400	
A-3 Fisch	250g	250	P80
	350g	350	
	450g	450	
A-4 Fleisch	250g	250	P100
	350g	350	
	450g	450	
A-5 Pasta	50 g(mit 450 g kaltem Wasser)	50	P80
	100 g(mit 800 g kaltem Wasser)	100	
A-6 Kartoffel	200g	200	P100
	400g	400	
	600g	600	
A-7 Pizza	200g	200	P100
	400g	400	
A-8 Suppe	200ml	200	P100
	400ml	400	

10. Sperrfunktion für Kinder

Diese Funktion verhindert, dass Kinder den Ofen versehentlich einschalten können.





Um die Sperre zu aktivieren:

Im Bereitschaftsmodus halten Sie "  " für drei Sekunden gedrückt. Es ertönt ein langer Piepton und "  " wird angezeigt.

Um die Sperre zu deaktivieren:

Im gesperrten Zustand halten Sie "  " für drei Sekunden gedrückt. Es ertönt ein langer Piepton.

11. Anfragefunktion

- (1) Wenn die Uhr eingestellt ist, wird durch Drücken von „  |  “ im Kochzustand die aktuelle Zeit für drei Sekunden angezeigt.
- (2) Im Mikrowellen-, Grill- oder Kombinationskochzustand drücken Sie „  +  “, um Informationen zur Leistungsstufe oder zum Kochmodus abzurufen. Es wird für drei Sekunden angezeigt.

STÖRBEHEBUNG

Normal	
Der Betrieb der Mikrowelle stört den Fernsehempfang	Während des Betriebs der Mikrowelle kann der Radio- und Fernsehempfang gestört sein. Dies ähnelt den Störungen kleiner elektrischer Geräte wie Mixer, Staubsaugern und Ventilatoren. Das ist normal.
Lampe ist dunkel	Bei Kochprogrammen der niedrigen Leistungsstufe kann die Beleuchtung dunkler werden. Das ist normal.
Dampf bildet sich an der Tür, heißer Dampf tritt aus den Belüftungsöffnungen aus	Während des Kochens erzeugen die Speisen heißen Dampf, der zum größten Teil über die Belüftungsöffnungen abgeleitet wird. Ein weiterer Teil kann sich an der kühleren Gerätetür absetzen. Das ist normal.
Gerät versehentlich ohne Speisen gestartet	Das Gerät darf nicht ohne Speisen gestartet werden. Dieser Zustand ist sehr gefährlich.

Problem	Mögliche Ursache	Behebung
Mikrowelle startet nicht	1) Netzkabel nicht richtig angeschlossen.	Trennen Sie das Netzkabel und schließen es nach 10 Sekunden erneut an.
	2) Sicherung durchgebrannt oder Leistungsschutzschalter aktiviert.	Ersetzen Sie die Sicherung oder stellen Sie den Leistungsschutzschalter zurück (muss von einer Fachkraft unserer Firma repariert werden).
	3) Steckdose fehlerhaft.	Schließen Sie zum Test andere elektrische Geräte an die gleiche Steckdose an.
Mikrowelle erhitzt nicht	4) Tür nicht richtig geschlossen.	Schließen Sie die Tür ordnungsgemäß.



Im Einklang mit der Richtlinie zur Entsorgung elektrischer und elektronischer Altgeräte (WEEE) müssen Altgeräte getrennt entsorgt und behandelt werden. Entsorgen Sie dieses Produkt zum gegebenen Zeitpunkt NICHT über den normalen Haushaltsmüll sondern geben Sie es an entsprechenden WEEE-Sammelstellen, sofern vorhanden, ab.

Mikrodalga Fırının KULLANMA KILAVUZU

Model: MWE FS20 G WH

Mikrodalga fırınınızı kullanmadan önce bu talimatları dikkatlice okuyun ve dikkatlice saklayın.

Talimatları takip ederseniz, fırınınız size uzun yıllar iyi hizmet sağlayacaktır.

BU KILAVUZU DİKKATLİCE SAKLAYIN

FAZLA MİKRODALGA ENERJİSİNE MARUZ KALMAYI ÖNLEMEK İÇİN ÖNLEMLER

- (a) Bu fırını kapısı açıkken çalıştırmaya çalışmayın çünkü bu mikrodalga enerjisine zararlı maruziyete neden olabilir. Güvenlik kilitlemelerini kırmamaya veya oynamamaya dikkat etmek önemlidir.
- (b) Fırın ön yüzü ile kapı arasına herhangi bir nesne koymayın veya sızdırmazlık yüzeylerinde toprak veya temizleyici kalıntı birikmesine izin vermeyin.
- (c) UYARI: Kapı veya kapı contaları hasar görmüşse, fırın yetkili bir kişi tarafından tamir edilene kadar çalıştırılmamalıdır.

EK

Cihaz temizlik durumunda tutulmazsa, yüzeyi bozulabilir ve cihazın ömrünü etkileyebilir, tehlikeli durumlara yol açabilir.

ÖZELLİKLER

Model	MWE FS20 G WH
Nominal Gerilim/Frekans	230 V~ 50 Hz
Mikrodalga Girişi	1050 W
Mikrodalga Çıkışı	700 W
Izgara	1000 W

ÖNEMLİ GÜVENLİK TALİMATLARI

UYARI

Cihazınızı kullanırken yangın, elektrik çarpması, kişilere zarar verme veya aşırı mikrodalga enerjisine maruz kalma riskini azaltmak için temel önlemleri izleyin,

bunlar arasında şunlar yer alır:

1. Aşırı mikrodalga enerjisine maruz kalmayı önlemek için belirli "AŞIRI MIKRODALGA ENERJİSİNE MARUZ KALMAYI ÖNLEME ÖNLEMLERİ"ni okuyun ve uygulayın.
2. Bu cihaz, 8 yaş ve üzeri çocuklar ile fiziksel, duyuusal veya zihinsel yetenekleri kısıtlı veya deneyim ve bilgi eksikliği olan kişiler tarafından güvenli bir şekilde kullanımı hakkında denetim veya talimat verildiyse ve tehlikelerin farkında iseler kullanılabilir. Çocuklar cihazla oynamamalıdır. Temizlik ve kullanıcı bakımı, denetimsiz çocuklar tarafından yapılmamalıdır.
3. Cihazı ve kablosunu 8 yaşından küçük çocukların erişemeyeceği bir yerde tutun.
4. Besleme kablosu hasar görmüşse, tehlikeleri önlemek için değiştirilmesi gerekmektedir; bunu üretici, servis acentesi veya benzer şekilde nitelikli kişiler yapmalıdır.
5. UYARI: Lambayı değiştirmeden önce cihazın kapalı olduğundan emin olun, elektrik çarpması olasılığını önlemek
6. UYARI: Mikrodalga enerjisine maruz kalmayı önleyen bir kapağın çıkarılmasını gerektiren herhangi bir servis veya tamir işleminin, yetkili olmayan kişiler tarafından yapılması tehlikelidir
7. UYARI: Sızdırmaz kaplarda sıvılar ve diğer yiyecekler ısıtılmamalıdır çünkü patlama tehlikesi vardır.
8. Plastik veya kağıt kaplarda yiyecek ısıtırken, dikkatli olun Fırının ateş alma olasılığı nedeniyle gözünüzü fırına dikin.

9. Sadece mikrodalga fırınlarda kullanıma uygun olan mutfak gereçlerini kullanın.
10. Eğer duman çıkarsa, cihazı kapatın veya fişi çekin ve herhangi bir alevi söndürmek için kapıyı kapalı tutun.
11. İçeceklerin mikrodalga fırında ısıtılması gecikmiş patlayıcı kaynamaya neden olabilir, bu nedenle kapın elle tutulması dikkatle yapılmalıdır.
12. Beslenme şişelerinin ve bebek mamalarının içeriği karıştırılmalı veya çalkalanmalı ve tüketilmeden önce sıcaklık kontrol edilmelidir, yanıklardan kaçınmak için.
13. Kabuklarıyla birlikte yumurtalar ve tam pişmiş yumurtalar mikrodalga fırında ısıtılmamalıdır çünkü patlayabilirler, hatta mikrodalga ısıtma sona erdikten sonra bile.
14. Fırın düzenli olarak temizlenmeli ve herhangi bir yiyecek artığı çıkarılmalıdır.
15. Fırının temiz bir durumda tutulmaması, cihazın ömrünü olumsuz etkileyebilecek bir yüzey bozulmasına yol açabilir ve muhtemelen tehlikeli bir duruma neden olabilir.
16. Cihazın aşırı ısınmayı önlemek için dekoratif bir kapının arkasına yerleştirilmemesi gerekmektedir. (Bu , dekoratif kapılı cihazlar için geçerli değildir.)
17. Bu fırın için önerilen sıcaklık probu kullanılmalıdır. (sıcaklık algılama probu kullanma olanağı sağlayan fırınlar için.)
18. Mikrodalga fırın bir dolaba yerleştirilmemelidir eğer bir dolapta test edilmediyse.
19. Mikrodalga fırın dekoratif kapı açıkken çalıştırılmalıdır. (dekoratif kapılı fırınlar için.)

20. Bu cihaz ev ve benzeri uygulamalarda kullanılmak üzere tasarlanmıştır:
- mağazalarda, ofislerde ve diğer çalışma ortamlarındaki personel mutfak alanları;
 - otellerde, motellerde ve diğer konut tipi ortamlarda müşteriler tarafından;
 - çiftlik evleri;
 - pansiyon tipi ortamlarda.
21. Mikrodalga fırın yiyecek ve içecekleri ısıtmak amacıyla tasarlanmıştır. Yiyecek veya giysilerin kurutulması ve ısıtma pedleri, terlikler, süngerler, nemli bez ve benzerlerinin ısıtılması yaralanma, tutuşma veya yangın riskine yol açabilir
22. Metal kaplar mikrodalga pişirme sırasında kullanılmamalıdır.
23. Cihaz buhar temizleyici ile temizlenmemelidir.
24. Cihaz serbest duran şekilde kullanılması amaçlanmıştır.
25. Cihazların arka yüzeyi bir duvara yerleştirilmelidir.

**DİKKATLİ OKUYUN VE GELECEKTE
BAŞVURU İÇİN SAKLAYIN YALNIZCA
EV KULLANIMI İÇİN (TİCARİ
KULLANIM DEĞİL)**

KİŞİLERE YARALANMA RİSKİNİ AZALTMAK TOZDAN ARINDIRMA KURULUMU TEHLİKE

Elektrik Çarpması Tehlikesi

Bazı iç bileşenlere dokunmak ciddi kişisel yaralanmalara veya ölüme neden olabilir. Bu cihazı sökmeyin.

UYARI

Elektrik Çarpması Tehlikesi

Topraklamanın yanlış kullanımı elektrik çarpmasına neden olabilir. Cihaz uygun şekilde kurulup topraklandıktan sonra prize takınız.

Bu cihaz topraklanmalıdır. Elektrik kısa devre oluştuğunda, topraklama elektrik çarpması riskini azaltarak elektrik akımı için bir kaçış telini sağlar.

Bu cihaz, bir topraklama fişi olan bir topraklama kablosuna sahiptir. Fiş, uygun şekilde kurulmuş ve topraklanmış bir prizde takılmalıdır.

Cihazın topraklama talimatları tam olarak anlaşılmazsa veya cihazın uygun şekilde topraklandığından şüphe ediliyorsa, nitelikli bir elektrikçiye veya servis elemanına danışın.

Bir uzatma kablosu kullanmak gerekiyorsa, yalnızca 3 telli bir uzatma kablosu kullanın.

1. Daha uzun bir kablo üzerinde takılarak veya tökezleyerek kaynaklanan riskleri azaltmak için kısa bir güç kablosu sağlanmıştır.
2. Uzun bir kablo takımı veya uzatma kablosu kullanılıyorsa:
 - a. Kablo takımının veya uzatma kablosunun üzerinde belirtilen elektrik derecelendirmesi, cihazın elektrik derecelendirmesinden en az kadar olmalıdır.
 - b. Uzatma kablosu topraklama tipi 3 telli bir kablo olmalıdır.

c. Uzun kablo, çocuklar tarafından çekilebilecek veya kazara tökezlebilecekleri tezgah üstüne veya masa üstüne sarkmayacak şekilde düzenlenmelidir.

TEMİZLİK

Cihazı güç kaynağından çektiğinizden emin olun.

1. Fırın boşluğunu hafif nemli bir bezle kullanıldıktan sonra temizleyin.
2. Aksesuarları normal şekilde sabunlu suyla temizleyin.
3. Kapı çerçevesi ve contası ve komşu parçalar kirli olduğunda dikkatlice hafif nemli bir bezle temizlenmelidir.
4. Fırın kapı camını temizlemek için sert aşındırıcı temizleyiciler veya keskin metal kazıyıcılar kullanmayın, çünkü yüzeyi çizebilir ve camın kırılmasına neden olabilir.
5. Temizlik İpuçları---Yiyeceğin temas edebileceği kavite duvarlarının daha kolay temizlenmesi için: Bir kaseye yarım limon koyun, 300ml (1/2 pint) su ekleyin ve %10 0 mikrodalga gücünde 10 dakika ısıtın. Fırını yumuşak, kuru bir bezle silin.

ARAÇLAR

DİKKAT

Kişisel Yaralanma Tehlikesi

Mikrodalga enerjisine maruziyeti önleyen bir kapağın çıkarılmasını gerektiren herhangi bir servis veya tamir işlemini yalnızca yetkili bir kişinin yapması tehlikelidir.

"Mikrodalga fırında kullanabileceğiniz malzemeler veya mikrodalga fırında kullanılmaması gereken malzemeler" hakkındaki talimatları inceleyin. Mikrodalga için güvenli olmayan belirli metal olmayan araçlar olabilir. Şüphemiz varsa, aşağıdaki prosedürü takip ederek söz konusu aracı test edebilirsiniz

Araç Testi:

- 1.Sorunlu aracı içeren 1 su bardağı soğuk suya (250ml) mikrodalga güvenli bir kap doldurun.
- 2.Maksimum güçte 1 dakika pişirin.
- 3.Eşyayı dikkatlice hissedin. Boş eşya ısınırsa, mikrodalga pişirme için kullanmayın.
- 4.1 dakikayı aşmayın pişirme süresi.

Mikrodalga fırında kullanabileceğiniz malzemeler

Mutfak gereçleri	Notlar
Kızartma kabı	Üreticinin talimatlarını takip edin. Kızartma kabının alt kısmı, döner tablanın en az 3/16 inç (5mm) üzerinde olmalıdır. Yanlış kullanım döner tablanın kırılmasına neden olabilir.
Yemek takımı	Sadece mikrodalga güvenli. Üreticinin talimatlarını takip edin. Çatlak veya kırık tabakları kullanmayın.
Cam kavanozlar	Her zaman kapağı çıkarın. Yiyeceği sadece hafifçe ısınınca ısıtmak için kullanın. Çoğu cam kavanoz ısıya dayanıklı değildir ve kırılabilir.
Cam eşyalar	Isıya dayanıklı fırın cam eşyaları sadece. Metalik kenar olmadığından emin olun. Çatlak veya kırık tabakları kullanmayın
Fırında pişirme torbaları	Üreticinin talimatlarını takip edin. Metal bağ ile kapatmayın. Buharın kaçmasına izin vermek için yarıklar açın.
Kağıt tabaklar ve bardaklar	Sadece kısa süreli pişirme/ısıtma için kullanın. Pişirme sırasında fırını başıboş bırakmayın.
Kağıt havlular	Yemekleri ısıtmak ve yağı emmek için kapak olarak kullanın. Kısa süreli pişirme için sadece gözetim altında kullanın.
Fırın kağıdı	Sıçramayı önlemek için kapak olarak veya buharla pişirme için saran olarak kullanın.
Plastik	Sadece mikrodalga güvenli. Üreticinin talimatlarını takip edin. "Mikrodalga Güvenli" olarak etiketlenmelidir. Bazı plastik kaplar, içindeki yiyecek ısındıkça yumuşar. "Kaynama torbaları" ve sıkıca kapatılmış plastik torbalar, pakette belirtildiği gibi yırtılmalı, delinmeli veya havalandırılmalıdır.
Plastik sargı	Sadece mikrodalga güvenli. Yemek pişirme sırasında nemin korunması için kullanın. Plastik saranın yiyeceğe temas etmesine izin vermeyin.
Termometreler	Sadece mikrodalga güvenli (et ve şeker termometreleri).
Yağlı kağıt	Sıçramayı önlemek ve nemini korumak için kapak olarak kullanın.

Mikrodalga fırında kullanılmaması gereken malzemeler

Mutfak gereçleri	Notlar
Alüminyum tepsi	Kıvılcıma neden olabilir. Yemeği mikrodalga güvenli tabağa aktarın.
Metal kulplu gıda kartonu	Kıvılcıma neden olabilir. Yemeği mikrodalga güvenli tabağa aktarın.
Metal veya metal kenarlı mutfak gereçleri	Metal gıdayı mikrodalga enerjisinden korur. Metal trim kıvılcıma neden olabilir.
Metal tel bağlar	Yanlış kullanım kıvılcımlara ve fırında yangına neden olabilir.
Kağıt poşetler	Fırında yangına neden olabilir.
Plastik köpük	Plastik köpük yüksek sıcaklığa maruz kaldığında eriyebilir veya içindeki sıvıyı kirletebilir.
Ahşap	Ahşap mikrodalga fırında kullanıldığında kuruyacak ve çatlayabilir.

FIRIN PARA VE AKSESUARLARININ İSİMLERİ

(Bu kılavuzdaki resimler ile cihaz arasında herhangi bir farklılık olması durumunda, ürün geçerli olacaktır.)

Fırını ve tüm malzemeleri kartondan ve fırın boşluğundan çıkarın.
Fırınınız aşağıdaki aksesuarlarla birlikte gelir:

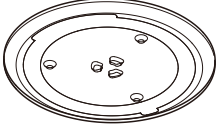

Cam Tepsi



Döner Tabla Halkası
Montajı



Kullanma Kılavuzu



Döner Tabla Mil

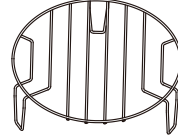

Izgara Rafı (Mikrodalga
fonksiyonunda kullanılamaz ve
cam tepsi üzerine yerleştirilmelidir)

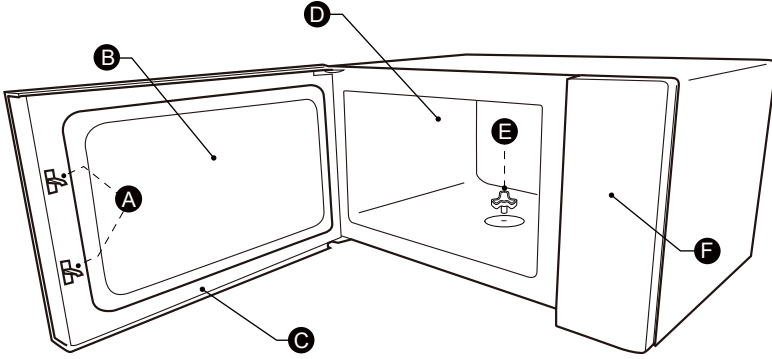

- A) Güvenlik kilitleme sistemi
B) Gözlem penceresi
C) Kapı montajı

- D) Fırın boşluğu
E) Döner tabla mil
F) Kontrol paneli

DÖNER TABLA MONTAJI

Pişirme bölmesini temizleme ve döner tablayı yerine koyma.

Yeni kurulumlar için, döner tabla milinden tüm ambalaj ve taşıma bandının çıkarıldığından emin olun. İlk kez yiyecek hazırlamak için cihazı kullanmadan önce, döner tablayı doğru şekilde yerine koymalısınız. Pişirme bölmesini ve aksesuarları temizlemelisiniz.

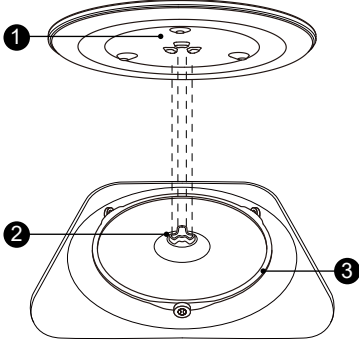

Döner tablayı nasıl yerleştireceğiniz:

1. Döner tabla halka montajını ③ pişirme bölmesindeki oyuk içine yerleştirin.
2. Cam tepsiyi ① döner tabla halka montajının ③ üzerine yerleştirin. Cam tepsinin altındaki yükseltilmiş, kavisli çizgileri, cam tepsi altındaki üç milin arasına yerleştirin. Cam tepsinin ① , pişirme bölmesi tabanının ortasındaki döner tabla miline ② oturduğundan emin olun. Mil üzerindeki silindirler, döner tabla alt kenarındaki çıkıntıya oturmalıdır

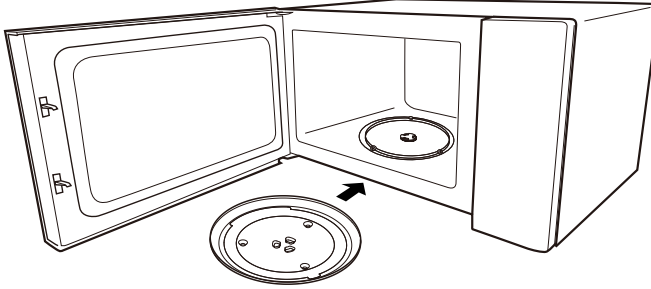

Notlar:

1. Döner tabla olmadan cihazı asla kullanmayın. Doğru şekilde bağlı olduğundan emin olun. Döner tabla saat yönünde veya saat yönünün tersine dönebilir.
2. Cam tepsinin asla ters çevrilmesi gerekmemektedir. Cam tepsinin hareketi asla kısıtlanmamalıdır.
3. Hem cam tepsi hem de döner tabla halka montajı her zaman pişirme sırasında kullanılmalıdır.
4. Tüm yiyecekler ve yiyecek kapları her zaman pişirme için cam tepsiye yerleştirilir.
5. Döner tablanın hareketini asla kısıtlamayın.
6. Cam tepsi veya döner tabla halka montajı çatladığında veya kırıldığında, en yakın yetkili servis merkezinizle iletişime geçin.

Tezgah Üstü Kurulum

Tüm ambalaj malzemelerini ve aksesuarları çıkarın.
Fırını, çizikler veya kırık kapı gibi herhangi bir hasar için inceleyin. Fırın hasarlıysa kurmayın.

Kabin: Mikrodalga fırın kabin yüzeyinde bulunan koruyucu filmi çıkarmayın.
Manyetronu korumak için fırın boşluğuna takılan dalga kılavuz kapağını çıkarmayın.

Kurulum

1. Düzgün bir seviyeli yüzey seçin ki Emiş ve/veya çıkış vantlar için yeterli açık alan sağlayın.

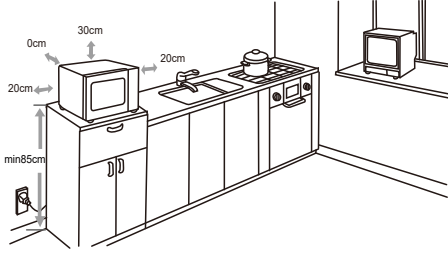

(1) Minimum kurulum yüksekliği 85cm'dir.
(2) Cihazın arka yüzeyi bir duvara yerleştirilmelidir. Fırının üstünde minimum 30cm boşluk bırakın, fırın ile herhangi bir yan duvar arasında minimum 20cm boşluk gereklidir.
(3) Fırının altındaki ayakları çıkarmayın.
(4) Emiş ve/veya çıkış açıklıklarını engellemek fırına zarar verebilir.

(5) Fırını mümkün olduğunca radyo ve televizyonlardan uzak bir yere yerleştirin. Mikrodalga fırının çalıştırılması radyo veya televizyon alıcınıza müdahale

2. Fırınızı standart bir ev prizine takın.





Gerilimin ve frekansın derecelendirme etiketinde belirtilen gerilim ve frekansla aynı olduğundan emin olun.
UYARI: Fırını ocak üstü veya diğer ısı üreten cihazların üzerine kurmayın. Eğer bir ısı kaynağına yakın veya üstüne yerleştirilirse, fırın hasar görebilir ve garanti geçersiz olabilir

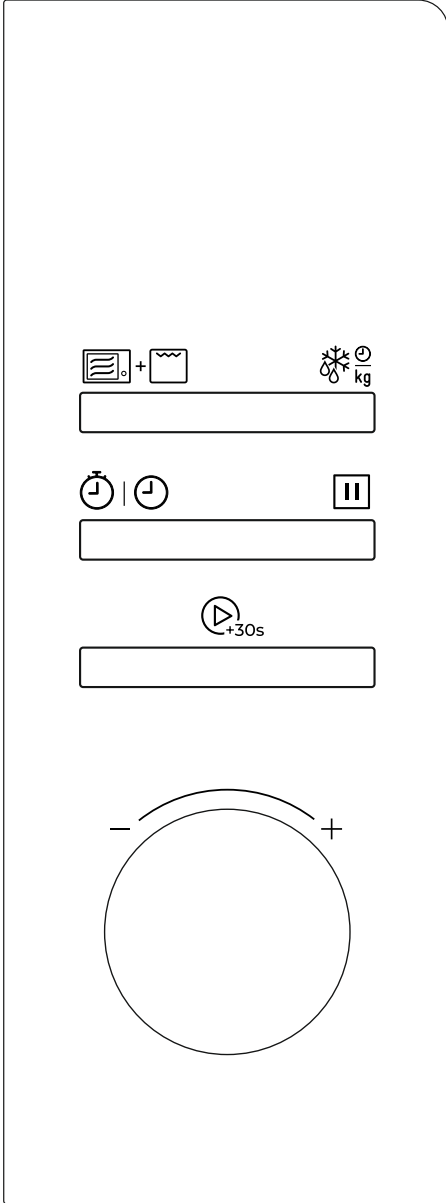

Erişilebilir yüzey işlem sırasında sıcak olabilir.

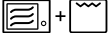



Panel de control





    **Fonksiyon**
(Mikrodalga+Izgara+Kombi)

  **Ağırlığa Göre Çözme/Süreye Göre Çözme**







  **Zamanlayıcı/Saat**

 **Durdur/Iptal**



  **Başlat/+30Sn./Hızlı Pişirme**

İŞLEM



1. Saati Ayarlama

- (1) Basın  |  " iki kez ve ardından "00:00" görüntülenir.
- (2) Saat rakamlarını ayarlamak için düğmeyi çevirin.
- (3) Basın "  |  " onaylamak için basın.
- (4) Dakika rakamlarını ayarlamak için düğmeyi çevirin.
- (5) Basın "  |  " onaylamak için. Saat ayarlandı.

Notlar:

- (1) Saat 24 saatlik bir ekrandır. Saat ayarlanmazsa, güç verildiğinde çalışmaz.
- (2) Saati sıfırlamak için lütfen adım 1'den adım 5'e kadar tekrarlayın.
- (3) Saati ayarladıktan sonra, "  |  " basılmazsa veya 1 dakika içinde işlem yapılmazsa, ayar geçersiz olur.

2. Mutfak Zamanlayıcısını Ayarlama







- (1) Basın "  |  " bir kez ve ardından "0:00" görüntülenir.
- (2) İstenen süreyi ayarlamak için düğmeyi çevirin. Maksimum süre değeri "95:00".
- (3) Basın "  " onaylamak için. Zamanlayıcı geri saymaya başlar.

Not: Mutfak zamanlayıcısı bir zamanlayıcıdır.



3. Mikrodalga Pişirme

Mikrodalga Güç Tablosu

Mikrodalga Gücü	100%	80%	50%	30%	10%
Ekran	P100	P80	P50	P30	P10



- (1) Basın "  +  " bir kez ve sonra "P100" görünecektir.
- (2) Basın "  +  " tekrarlayarak veya düğmeyi çevirerek güç seviyesini ayarlayın. 5 güç seviyesi mevcuttur.
- (3) Basın "  " onaylamak için basın.
- (4) Düğmeyi çevirerek pişirme süresini ayarlayın. Maksimum süre değeri "95:00".
- (5) Basın "  " ile pişirmeyi başlatın

4. Ağırlığa Göre Çözme

- (1) Basın "   kg " bir kez basınca, ekran "dEF1" görünecektir.
- (2) Düğmeyi çevirerek yiyeceğin ağırlığını ayarlayın. Ağırlık aralığı 100-2000g.
- (3) Basın "  +30s " ile çözmeye başlayın.

Not: Çözülme sırasında yiyeceği çevirmeniz gerektiğini hatırlatmak için alarm çalacaktır.
Herhangi bir işlem yapılmazsa, fırın çalışmaya devam eder.



5. Zamanına Göre Çözme

- (1) Basın "   kg " iki kez basınca, ekran "dEF2" görünecektir.
- (2) Düğmeyi çevirerek istenen çözme süresini ayarlayın. Maksimum süre değeri "95:00".
- (3) Basın "  +30s " ile çözmeye başlayın.

Notlar:

- (1) Çözülme sırasında yiyeceği çevirmeniz gerektiğini hatırlatmak için alarm çalacaktır.
Herhangi bir işlem yapılmazsa, fırın çalışmaya devam eder.
- (2) Çözme gücü P30'dur ve değiştirilemez.

6. Hızlı Pişirme

- (1) Bekleme modundayken, basın "  +30s " yi 100% güç seviyesinde 30 saniye pişirin.
Aynı tuşa her basış 30 saniye artırabilir ve maksimum süre değeri "95:00" olacaktır.
- (2) Bekleme modundayken, 100% güçle pişirme süresini ayarlamak için düğmeyi sola çevirin. Pişirme süresini ayarlamak için düğmeyi çevirmeye devam edin .
Maksimum süre değeri "95 :00" dır. Sonra " tuşuna basın "  +30s " ile pişirmeyi başlatın.

Not: Pişirme durumunda ve zamanla çözülme durumunda, her bir daha fazla basış

"  +30s " mikrodalga fırınına 30 saniye daha uzatabilir (ağırlığa göre çözülme, otomatik menü ve çoklu aşamalı pişirme ilk aşaması hariç).

7. Çoklu Aşamalı Pişirme

Notlar: (1) Çoklu aşamalı pişirmede iki pişirme aşaması ayarlanabilir.

(2) Çözme işlevini ayarlarsanız, bu otomatik olarak ilk aşamada çalışacaktır.



(3) Mutfak zamanlayıcısı, otomatik menü çoklu aşamalı pişirme olarak ayarlanamaz.

Örnek: Yiyeceği 5 dakika çözün ve ardından 7 dakika %80 mikrodalga gücüyle pişirin.

(1) Basın "   " iki kez basınca, ekran "dEF2" görünecektir.

(2) Arzu edilen çözme süresini 5 dakika olarak ayarlamak için düğmeyi çevirin.

(3) Basın "  +  " bir kez ve ardından "P100" görünecektir.

(4) Basın "  +  " tekrar veya güç seviyesini P80 olarak ayarlamak için düğmeyi çevirin.



(5) Basın "  +30s " onaylamak için basın.

(6) Pişirme süresini 7 dakika olarak ayarlamak için düğmeyi çevirin.

(7) Basın "  +30s " ile pişirmeyi başlatın.

8. Izgara ve Kombinasyon Pişirme

(1) Basın "  +  " bir kez ve sonra "P100" görünecektir.

(2) Basın "  +  " tekrarlayarak veya sırasıyla "G-1", "C-1" ve "C-2" görüntülenecek şekilde düğmeyi çevirerek.

(3) Basın "  +30s " onaylamak için basın.

(4) Düğmeyi çevirerek pişirme süresini ayarlayın. Maksimum süre değeri "95:00".

(5) Basın "  +30s " ile pişirmeyi başlatın.



Not: Izgara pişirme sırasında yiyeceği çevirmeniz gerektiğini hatırlatmak için çingirak sesi duyulacaktır.

Herhangi bir işlem yapılmazsa, fırın çalışmaya devam eder.

Kombinasyon Pişirme Tablosu

Fonksiyon	Ekran	Mikrodalga Gücü	Izgara Gücü
Combi. 1	C-1	55%	45%
Combi. 2	C-2	36%	64%

9. Otomatik Menü



- (1) Düğmeyi sağa çevirin ve ardından "A-1" görünecektir.
- (2) İhtiyacınız olan menüyü seçmek için düğmeyi çevirmeye devam edin. 8 otomatik menü mevcuttur.
- (3) Basın "  " onaylamak için basın.
- (4) Düğmeyi çevirerek yiyeceğin ağırlığını ayarlayın.
- (5) Basın "  " ile pişirmeyi başlatın.

Otomatik Menü Tablosu

Menü	Ağırlık	Ekran	Güç
A-1 Otomatik Yeniden Isıtma	200g	200	P100
	400g	400	
	600g	600	
A-2 Sebze	300g	300	P100
	400g	400	
A-3 Balık	250g	250	P80
	350g	350	
	450g	450	
A-4 Et	250g	250	P100
	350g	350	
	450g	450	
A-5 Makarna	50g(con 450g soğuk su ile)	50	P80
	100g(con 800g soğuk su ile)	100	
A-6 Patates	200g	200	P100
	400g	400	
	600g	600	
A-7 Pizza	200g	200	P100
	400g	400	
A-8 Çorba	200ml	200	P100
	400ml	400	

10. Çocuklar için Kilit Fonksiyonu

Çocukların fırını yanlışlıkla açmasını önlemek için bu fonksiyonu kullanabilirsiniz. Kilidi etkinleştirmek için:

Bekleme modunda, "  " tuşuna üç saniye basılı tutun. Uzun bir bip sesi duyulur ve "  " görüntülenecektir.



Kilidi devre dışı bırakmak için:

Kilitli durumdayken, basılı tutun "  " üç saniye boyunca. Uzun bir bip sesi duyulur.

11. Sorgulama Fonksiyonu

(1) Saat ayarlanmıŖsa, mevcut zamanı göstermek için üç saniye boyunca basın

"  |  "piŖirme durumunda.

(2) Mikrodalga, ızgara, kombinasyon piŖirme durumunda, tuŖuna basın "  +  " hakkında bilgi almak için güç seviyesi veya piŖirme modu. Üç saniye boyunca görüntülenecek.

Sorun giderme

Normal	
Mikrodalga fırın yayını TV alımını etkiler	Radyo ve TV alımı, mikrodalga fırın çalışırken etkilenebilir. Mikser, elektrik süpürgesi ve vantilatör gibi küçük elektrikli aletlerin etkileşimiyle benzerdir. Normaldir.
Kısık fırın ışığı	Düşük güç mikrodalga pişirme sırasında fırın ışığı soluklaşabilir. Bu normaldir.
Kapıda biriken buhar, havalandırmalardan sıcak hava çıkar	Pişirme sırasında yiyecten buhar çıkabilir. Çoğu havalandırmalardan çıkacaktır. Ancak bazıları fırın kapısı gibi serin bir yere birikebilir. Bu normaldir.
Fırın kazara yiyecek olmadan başlatıldı.	Ünitenin içinde yiyecek olmadan çalıştırılması yasaktır. Çok tehlikelidir.

Sorun	Muhtemel Neden	Çözüm
Fırın başlatılamaz	(1) Güç kablosu sıkıca takılmamış.	Fişi çekin. Ardından 10 saniye sonra tekrar takın.
	(2) Sigorta atıyor veya devre kesici çalışıyor.	Sigortayı değiştirin veya devre kesiciyi sıfırlayın (şirketimizin profesyonel personeli tarafından onarılmıştır
	(3) Prizde sorun.	Diğer elektrikli aletlerle prizi test edin.
Fırın ısınmıyor.	(4) Kapı iyi kapanmıyor.	Kapıyı iyi kapatın.



Elektrikli ve Elektronik Eşya Atıklarının Kontrolü Yönetmeliğine (WEEE) göre, WEEE ayrı olarak toplanmalı ve işlenmelidir. Gelecekte bu ürünü herhangi bir zamanda imha etmeniz gerektiğinde lütfen bu ürünü ev atıklarıyla birlikte imha etmeyin. Lütfen bu ürünü mevcut olduğunda WEEE toplama noktalarına gönderin.

Teka Subsidiaries

Country	Subsidiary	Address	City	Phone
Austria	Küppersbusch Austria	Eitnergasse, 13	1231 Wien	+43 18 668 022
Belgium	Küppersbusch Belgium S.P.R.L.	Doomveld Industrie, Asse 3, No. 11 - Boite 7	1731 Zellik	+32 24 668 740
Bulgaria	Teka Bulgaria EOOD	Bldv. "Tsarigradsko Shosse" 135	1784 Sofia	+359 29 768 330
Chile	Teka Chile S.A.	Avd El Retiro Parque los Maitenes, 1237. Parque Enea	Pudahuel, Santiago de Chile	+56 24 386 000
China	Teka International Trading (Shanghai) Co. Ltd.	No.1506, Shengyuan Henghua Bldg, No.200 Wending Rd.	Xuhui, Dist. 200030 Shanghai	+86 2 153 076 996
Czech Republic	Teka CZ S.R.O.	V Holesovickách, 593	182 00 Praha 8 - Liben	+420 284 691 940
Ecuador	Teka Ecuador S.A.	Parque Ind. California 2, Via a Daule Km 12	Guayaquil	+593 42 100 311
Greece	Teka Hellas A.E.	Thesi Roupaki - Aspropyrgos	193 00 Athens	+30 2 109 760 283
Hungary	Teka Magyarországi Zrt.	Terv u. 92	9200 Mosonmagyaróvár	+36 96 574 500
Indonesia	PT Teka Buana	Jalan Menteng Raya, Kantor Taman A9 Unit A3	12950 Jakarta	+62 215 762 272
Malaysia	Teka Küchentechnik (Malaysia) Sdn Bhd	10 Jalan Kartunis U1/47, Temasya Park, Off Glenmarie	40150 Shah Alam, Selangor Darul Ehsan	+60 376 201 600
Mexico	Teka Mexicana S.A. de C.V.	Bldv Manuel A. Camacho 126, Piso 3 Col. Chapultepec	11000 Mexico D.F.	+52 5 551 330 493
Morocco	Teka Maroc S.A.	73, Bd. Slimane, Dépôt 33, Route de Ain Sebaa	Casablanca	+212 22 674 462
Peru	Teka Küchentechnik Perú S.A.	Av. El Polo 670 local A 201, CC El polo, Surco	Lima	+51 14 363 078
Poland	Teka Polska Sp. ZO.O.	ul. 3-go Maja 8 / A2	05-800 Pruszkow	+48 227 383 270
Portugal	Teka Portugal S.A.	Estrada da Mota - Appdo 533	3834-909 Ilhavo, Aveiro	+35 1 234 329 500
Romania	S.C. Teka Küchentechnik Romania S.R.L.	Sevastopol str., no 24, 5th floor, of. 15	010992 Bucharest Sector 1	+40 212 334 450
Russia/Россия	Teka Rus LLC/OOO "Теха Рус"	Neverovskogo 9, Office 417, 121170, Moscow, Russia	121087 Россия, Москва	+7 4 956 450 064
Singapore	Teka Singapore PTE Ltd	Clemenceau Avenue, 83, 01-33/34 UE Square	239920 Singapore	+65 67 342 415
Spain	Teka Industrial, S.A.	C/ Cajo,17	39011 Santander	+34 942 355 050
Thailand	Teka (Thailand) Co. Ltd.	364/8 Sri-Ayuttaya Road, Phayathai, Ratchatavee	10400 Bangkok	+66 -26 424 888
Turkey	Teka Teknik Mutfak Aletleri Sanayi Ve	Büyükdere Cad. 24/13	80290 Mecidiyeköy, Istanbul	+90 2 122 883 134
Ukraine	Teka Ukraine LLC	86-e, Bozhenko Str. 2nd floor, 4th entrance	03150 Kyiv	+380 444 960 680
United Arab Emirates	Teka Middle East Fze	Building LOB 16, Office 417	P.O. Box 18251 Dubai	+971 48 872 912
United Arab Emirates	Teka Küchentechnik U.A.E LLC	Bin Khedia Centre	P.O. Box 35142 Dubai	+971 42 833 047
Venezuela	Teka Andina S.A.	Ctra. Petare-Santa Lucia, km 3 (El Limoncito)	1070 Caracas	+58 2 122 912 821
Vietnam	TEKA Vietnam Co., Ltd.	803, F1 8th, Daiminh Convention Center, 77, Hoang Van	Thai, Tan Phu Ward, District 7, Ho Chi Minh	+84 854 160 646



TEKA

Teka Industrial S.A.
C/Cajo, 17 – 39011, Santander (Cantabria), España.

teka.com

"for further information and updated contact addresses, please refer to the corporate website"



teka.com

Asped mos eriatius sit atet hicil et velit