



**MANUALE D'USO**

TOSTAPANE 2 E 4 FETTE

**INSTRUCTION MANUAL**

2 SLICE AND 4 SLICE TOASTER

**MANUEL D'UTILISATION**

GRILLE-PAIN 2 ET 4 TRANCHES

**BEDIENUNGSHANDBUCH**

2- UND 4-SCHEIBEN-TOASTER

**GEBRUIKSAANWIJZING**

BROODROOSTER 2 EN 4 BOTERHAMMEN

**MANUAL DE USO**

TOSTADORA DE 2 Y 4 REBANADAS

**MANUAL DE UTILIZAÇÃO**

TOSTADEIRA DE 2 E 4 FATIAS

**BRUKSANVISNING**

BRÖDROST 2 OCH 4 SKIVOR

**РУКОВОДСТВО ПО ЭКСПЛУАТАЦИИ**

ТОСТЕР НА 2 И 4 ЛОМТИКА

**BRUGERVEJLEDNING**

BRØDRISTER TIL 2 OG 4 SKIVER

**INSTRUKCJA OBSŁUGI**

TOSTER NA 2 LUB 4 KROMKI

**KÄYTTÖOPAS**

LEIVÄNPAAHDIN 2 JA 4 VIIPALETTA

**BRUKSANVISNING**

BRØDRISTER 2 OG 4 SKIVER

**دليل التعليمات**

محمصة ثنائية القطعة ورباعية القطعة

IT  
EN  
FR  
DE  
NL  
ES  
PT  
SV  
RU  
DA  
PL  
FI  
NO  
AR



**Informazioni importanti per l'utente, Important information for the user,  
Informations importantes pour l'utilisateur, Wichtige Informationen für  
den Benutzer, Belangrijke informatie voor de gebruiker, Información  
importante para el usuario, Informações importantes para o utilizador,  
Viktig information för användaren, Важная информация для  
пользователя, Vigtig information til brugeren, Ważne informacje dla  
użytkownika, Tärkeitä tietoja käyttäjälle, Viktig informasjon for brukere,  
معلومات هامة للمستخدم**



**Avvertenze / Recommendations / Avertissements / Hinweise / Waarschuwingen  
/ Advertencias / Advertências / Varningar / Меры предосторожности /  
Advarsler / Ostrzeżenia / Varoitukset / Advarsler / تحذيرات**



**Descrizione / Description / Description / Beschreibung / Beschrijving /  
Descripción / Descrição / Beskrivning / Описание / Beskrivelse / Opis /  
Kuvaus / Bekrivelse / الوصف**



**Uso / Use / Utilisation / Gebrauch / Gebruik / Uso / Utilização / Användning /  
Использование / Anvendelse / Użytkowanie / Käyttö / Bruk / الإستعمال**



**Pulizia e manutenzione / Cleaning and care / Nettoyage et entretien /  
Reinigung und Wartung / Reiniging en onderhoud / Limpieza y mantenimiento /  
Limpeza e manutenção / Rengöring och underhåll / Чистка и техническое  
обслуживание / Rengøring og vedligeholdelse / Czyszczenie i konserwacja /  
Puhdistus ja hoito / Rengjøring og vedlikehold / التنظيف و الصيانة**



**Avvertenza di sicurezza / Safety instructions / Consignes de sécurité /  
Sicherheitshinweise / Veiligheidswaarschuwingen / Advertencia de seguridad  
/ Advertências de segurança / Säkerhetsvarning / Предупреждение о  
безопасности / Sikkerhedsanvisninger / Ostrzeżenie dotyczące bezpieczeństwa  
/ Turvallisuuteen liittyvät varoitukset / Sikkerhetsadvarsler / تحذير للسلامة**



**Informazione / Information / Information / Information / Informatie /  
Información / Informação / Information / Информация / Information /  
Informacja / Tietoa / Informasjon / معلومات**



**Suggerimento / Advice / Conseil / Empfehlungen / Aanbeveling /  
Sugerencia / Sugestões / Råd / Рекомендация / Forslag / Porada /  
Neuvo / Forslag / اقتراحات**

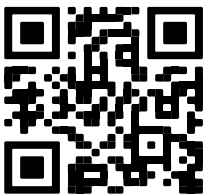

**MY SMEG  
ASSISTANT**

Scansiona il QR code per un accesso rapido al portale My Smeg Assistant  
Scan the QR code for quick access to the My Smeg Assistant portal  
Scannez le code QR pour un accès rapide au portail My SMEG Assistant  
Für den schnellen Zugriff auf das Portal MySmegAssistant scannen Sie einfach den QR-Code  
Scan de QR-code voor de Handleiding voor Snelle Installatie en Onderhoud  
Escanee el código QR para acceder rápidamente al portal My Smeg Assistant  
Leia o Código QR para ter acesso rápido ao portal My Smeg Assistant  
Skanna QR-koden för att snabbt öppna portalen My Smeg Assistant  
Отсканируйте QR-код для быстрого доступа к portalу My Smeg Assistant  
Scan QR-koden for hurtigt at få adgang til portalen My Smeg Assistant  
Zeskanuj kod QR, aby uzyskać szybki dostęp do portalu My Smeg Assistant  
Skannaa QR-koodi, jonka avulla pääset nopeasti My Smeg Assistant -portaaliin  
Skann QR-koden for hurtig tilgang til portalen My Smeg Assistant

اسمح رمز الاستجابة السريعة من أجل الوصول بسرعة إلى بوابة الدعم My Smeg Assistant

Gentile Cliente, La ringraziamo vivamente per il Suo acquisto. I nostri prodotti sono unici perché uniscono una spiccata ricerca estetica alla progettazione tecnica innovativa. Essi sono coordinati con altri prodotti in gamma e possono costituire elementi d'arredo e di design. Augurandole di apprezzare appieno le funzionalità del Suo elettrodomestico, Le porgiamo i nostri più cordiali saluti.

Dear Customer, Thank you for purchasing one of our appliances. Our products are unique because they combine iconic style with innovative technical solutions. They match perfectly with other products in our range and work equally well as a standalone design objects in your kitchen. We hope you enjoy using your new appliance! Best regards.

Cher client, merci beaucoup pour votre achat. Nos produits sont uniques car ils combinent une forte recherche esthétique avec une conception technique innovante. Ils sont coordonnés avec d'autres produits de la gamme et peuvent constituer des éléments d'ameublement et de design. En espérant que vous pourrez apprécier pleinement votre nouvel appareil électroménager, nous vous adressons nos meilleures salutations.

Sehr geehrter Kunde, wir danken Ihnen herzlich für den Kauf. Unsere Produkte sind einzigartig, da sich in ihnen eine gewissenhafte Designforschung und eine innovative technische Planung vereinen. Sie sind mit anderen Produkten des Sortiments kombinierbar und stellen ausgefallene Einrichtungs- und Designgegenstände dar. Wir hoffen, dass Sie Ihr neues Haushaltsgerät voll und ganz schätzen werden und verbleiben mit freundlichen Grüßen.

Beste klant, hartelijk dank voor uw aankoop. Onze producten zijn uniek omdat ze esthetiek combineren met innovatief technisch ontwerp. De producten zijn uitstekend te combineren andere producten van het assortiment en kunnen worden gebruikt als meubel- en designelementen. We hopen dat u volop van uw nieuwe huishoudelijke apparaat zult genieten. Met vriendelijke groet

Estimado cliente, le damos las gracias por su compra. Nuestros productos son únicos porque combinan una notable búsqueda estética con un diseño técnico innovador. Se combinan con otros productos de la gama y se pueden utilizar como elementos de decoración y diseño. Le deseamos que pueda apreciar plenamente su nuevo electrodoméstico. Le enviamos nuestros saludos más cordiales.

Prezado cliente, Muito obrigado pela sua compra. Os nossos produtos são únicos porque combinam uma forte busca estética com um desenho técnico inovador. São coordenados com outros produtos da linha e podem constituir elementos de decoração e design. Esperando que possa desfrutar totalmente das funcionalidades do seu eletrodoméstico, enviamos-lhe os nossos melhores cumprimentos.

Bäste kund, vi vill tacka dig för ditt köp. Våra produkter är unika eftersom de kombinerar ett estetiskt nytänkande med innovativ teknik. Våra produkter passar med de andra i samma serie och kan användas som föremål inom heminredningen för att ge en särskild känsla av stil i ditt hem. Vi hoppas att du till fullo kommer att uppskatta funktionerna hos din hushållsmaskin. Med bästa hälsningar.

Уважаемый покупатель! Благодарим Вас за покупку. Наши изделия уникальны, поскольку они сочетают в себе великолепный дизайн и передовые технические решения. Кроме того, они комбинируются с другими изделиями из этой линейки и могут стать стильными элементами интерьера и дизайна. Надеемся, что Вы в полной мере оцените функциональные возможности Вашего бытового прибора. С наилучшими пожеланиями.

Kære Kunde, mange tak for dit køb. Vores produkter er unikke, da de forener æstetisk research og innovativt teknisk design. De passer perfekt sammen med de andre produkter i serien, og kan stå som et enkeltstående møbel af design. Vi håber, at du vil værdsætte din hårde hvidevares funktionalitet, og sender de bedste hilsener.

Szanowny Kliencie, Dziękujemy za Twój zakup. Nasze produkty są wyjątkowe, ponieważ łączą intensywne badania estetyczne z innowacyjnym projektem technicznym. Są one skoordynowane z innymi produktami z asortymentu i mogą stanowić elementy wyposażenia i wystrój. Mamy nadzieję, że będą Państwu mogli w pełni korzystać z funkcjonalności tego urządzenia. Serdecznie pozdrawiamy.

Arvoisa Asiakas, kiitämme sinua hankintasi johdosta. Tuotteemme ovat ainutlaatuisia, koska niissä yhdistyvät esteettisyys ja innovatiivinen tekninen suunnittelu. Ne sopivat yhteen muiden valikoimaan kuuluvien tuotteiden kanssa toimien samalla sisustus- ja design-tuotteina. Toivomme, että voit nauttia täysin siemauksin kodinkoneesi toiminnoista. Sydämellisin terveisin.

Kjære kunde. Vi takker for at dere valgte å kjøpe et av våre produkter. Våre produkter er unike fordi de forener søken etter estetikk med en nyskapende teknisk design. De koordineres med andre produkter i vårt sortiment og kan ha funksjon som både møbel- og designvare. Vi håper du får fullt utbytte av ditt husholdningsapparat, og sender deg våre beste hilsener.

تحتفظ جهة التصنيع بحقها في إجراء أية تغييرات تراها ضرورية لتحسين منتجاتها دون إخطار مسبق. لذا، تعتبر الرسوم التوضيحية والأوصاف الواردة في هذا الدليل غير ملزمة ولكنها إرشادية فقط.

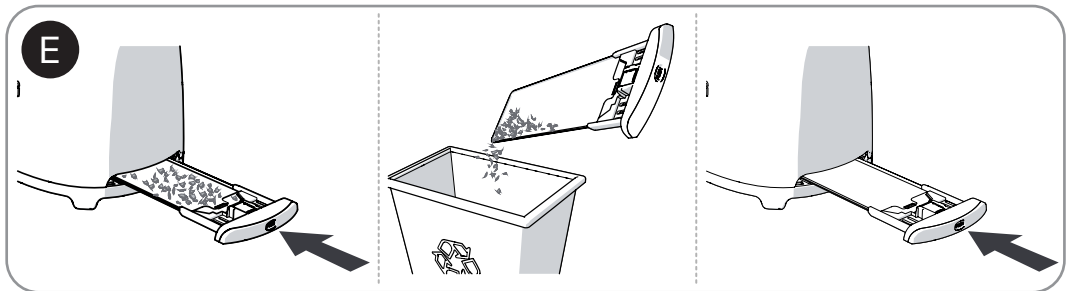
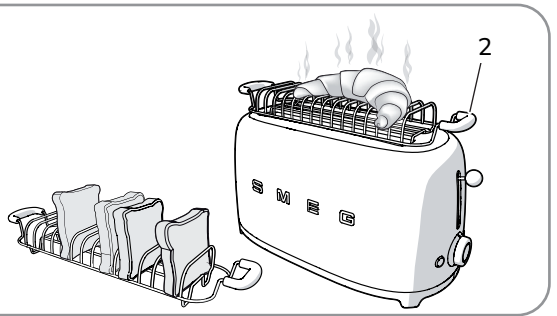
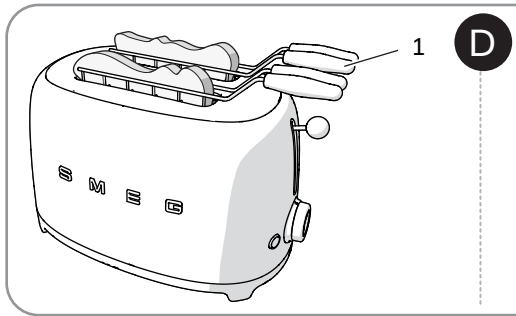
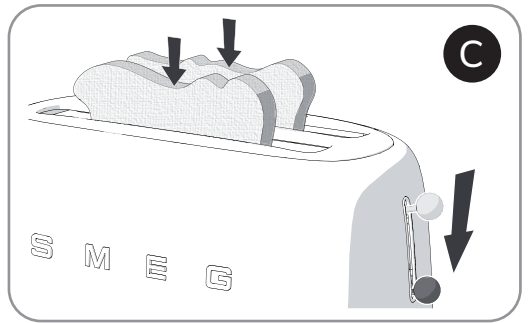
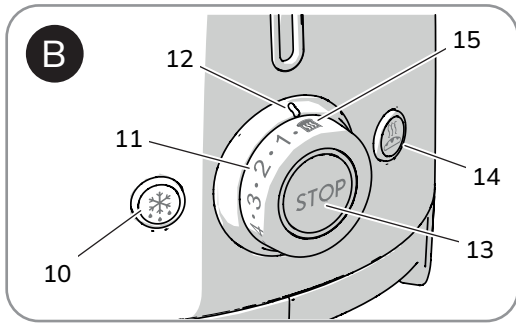
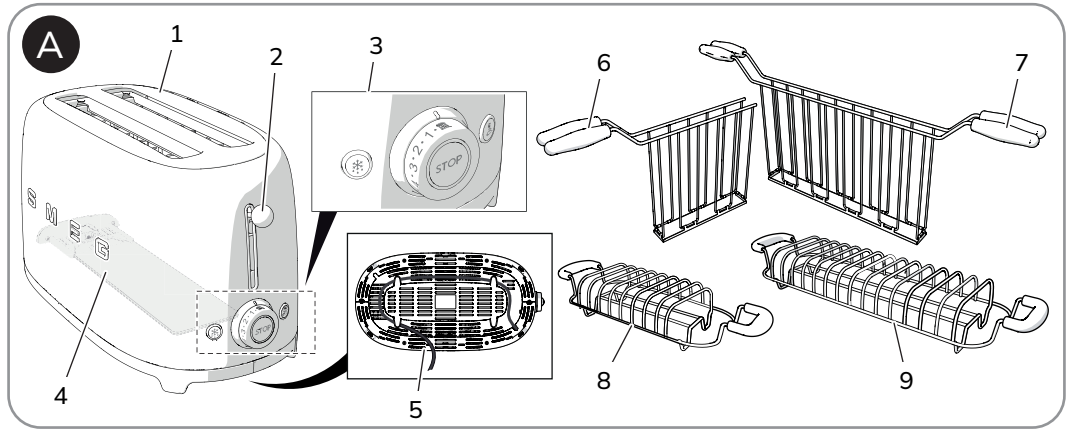

Il costruttore si riserva di apportare senza preavviso tutte le modifiche che riterrà utili al miglioramento dei propri prodotti. Le illustrazioni e le descrizioni contenute in questo manuale non sono quindi impegnative ed hanno solo valore indicativo.

The manufacturer reserves the right to make any changes deemed necessary for the improvement of its products without prior notice. The illustrations and descriptions contained in this manual are therefore not binding and are merely indicative.

Le fabricant se réserve la faculté d'apporter, sans préavis, toutes les modifications qu'il jugera utiles pour l'amélioration de ses produits. Les illustrations et les descriptions figurant dans ce manuel ne sont pas contraignantes et n'ont qu'une valeur indicative.

Der Hersteller behält sich vor, ohne vorherige Benachrichtigung alle Änderungen vorzunehmen, die er zur Verbesserung seiner Produkte für nützlich erachtet. Die in diesem Handbuch enthaltenen Illustrationen und Beschreibungen sind daher unverbindlich und dienen nur zur Veranschaulichung.

De fabrikant behoudt zich het recht voor zonder waarschuwing alle wijzigingen aan te brengen die hij nodig acht om zijn producten te verbeteren. De afbeeldingen en de beschrijvingen die aanwezig zijn in deze handleiding zijn niet bindend, en hebben enkel een aanduidende waarde.

El fabricante se reserva el derecho a aportar sin aviso previo todas las modificaciones que considere útiles para la mejora de sus propios productos. Las ilustraciones y las descripciones contenidas en este manual no son vinculantes y tienen solo valor indicativo.

O fabricante reserva-se o direito de efetuar, sem aviso prévio, qualquer modificação que vise o melhoramento dos respetivos produtos. As ilustrações e descrições contidas neste manual não são, por isso, vinculativas e possuem apenas valor indicativo.

Tillverkaren förbehåller sig rätten att genomföra alla de ändringar som anses nödvändiga för att förbättra de egna produkterna utan att meddela detta i förväg. De illustrationer och beskrivningar som finns i aktuell manual är därmed inte bindande utan endast indikativa.

Для улучшения выпускаемой продукции изготовитель оставляет за собой право вносить без предварительного предупреждения любые изменения, которые он сочтет целесообразными. Рисунки и описания, содержащиеся в данном руководстве, не являются обязывающими и носят ознакомительный характер.

Fabrikanten forbeholder sig retten til, uden varsel, at udføre alle de ændringer, der vurderes nyttige for at forbedre egne produkter. Tegningerne og beskrivelserne i denne manual er derfor kun vejledende og ikke bindende.

Producent zastrzega sobie prawo do nanoszenia, bez uprzedniego powiadomienia, wszelkich zmian, które uzna za stosowne w celu ulepszenia swoich produktów. Rysunki i opisy zawarte w niniejszej instrukcji nie są zobowiązujące i mają jedynie charakter orientacyjny.

Valmistaja pidättää itsellään oikeuden tehdä ohjeisiin mielestään tarpeellisia muutoksia ilman ennakoilmoitusta. Tässä oppaassa olevat kuvat ja piirrokset eivät näin ollen ole sitovia, vaan ne annetaan vain viitteellisessä mielessä.

Produsenten forbeholder seg rett til å foreta endringer på sine produkter grunnet tekniske fremskritt, uten forutgående varsel. Illustrasjonene og beskrivelsene i denne bruksanvisningen er derfor ikke bindende og skal kun betraktes som retningsgivende.

عملينا العزيز، شكرا لك على شراء أحد أجهزتنا. تعد منتجاتنا فريدة لأنها تجمع بين الأسلوب المميز والحلول التقنية المبتكرة. وهي تتناسب تماما مع المنتجات الأخرى في مجموعتنا وتعمل بنفس القدر كتصميمات قائمة بذاتها في مطبخك. نأمل أن تستمتع باستخدام هذا الجهاز الجديد! وتفضلوا بقبول وافر الاحترام والتقدير.



## 1 Instructions

This user manual is an integral part of the appliance and must therefore be kept in its entirety and within the user's reach for the whole working life of the appliance.

### 1.1 Intended use

- Use the appliance only indoors.
- This appliance is intended for household use and similar applications such as:
  - staff kitchen areas in shops, offices and other working environments
  - bed and breakfast facilities / farm accommodation
  - by guests in hotels, motels and other residential accommodations
- Any other use, for example in restaurants, coffee bars and coffee shops is considered improper.
- It can only be used for toasting bread. Do not use the appliance for anything other than the intended use.
- Carefully follow the notes and suggestions provided in the user manual.
- Only use the appliance for toasting bread.
- The appliance can also be used for preparing toasted sandwiches but only if the specific sandwich racks are used (sold separately).
- If food or other substances were to come in to contact with the heating elements they may cause unpleasant odours, smoke and damage the appliance.
- The appliance is not designed to operate with external timers or with remote-control systems.
- This appliance may be used by children aged at least 8 and by people of reduced physical and mental capacity, or lacking in experience in the use of electrical appliances, as long as they are supervised or instructed by adults who are responsible for their safety.

- Children must never play with the appliance. Keep the appliance out of children's reach.

### 1.2 General safety instructions

Follow all safety instructions in order to be able to use the appliance safely.

- Do not immerse the appliance, the power cord or the plug in water or any other liquid.
- Do not use the appliance when the power cord or the plug is damaged or when the appliance has fallen or is damaged in any manner.
- Do not place the appliance on or near a burning gas or an electrical stove or in a heated oven.
- The cord is short to prevent accidents. Do not use an extension cord.
- In case of a fault repairs should only be carried out by a qualified engineer.
- Switch off the appliance immediately after use.
- Never try to put out a fire or flames with water: turn off the appliance, remove the plug from the socket and smother the flames with a fire blanket or any other appropriate cover.
- Read this user manual carefully before using the appliance.
- Do not modify this appliance.
- Do not try to repair the appliance yourself or without the intervention of a qualified engineer.
- If the power supply cable is damaged, contact technical support immediately.



# Instructions

## 1.3 For this appliance

- The toaster can get very hot when it is operating. Do not touch any hot surfaces. Use the control knob and functions, the breadlift and optional accessories.
- Remove the plug from the socket when toaster is not in use, before cleaning and in case of fault. Let it cool down before cleaning.
- Bread may burn. Therefore do not use the appliance near or below combustible materials, such as curtains.
- Make sure the breadlift is elevated before you plug in or remove the plug.
- Make sure that the air around the toaster can circulate freely. Do not place anything on top of the toaster.
- Do not try to remove food from the toaster when it is still operating.
- Never rest metallic objects such as knives, forks, spoons on the appliance during use.
- Never use metallic objects such as knives, forks, spoons to clean the toaster.
- The appliance must never be cleaned by unsupervised children.

### Information on power consumption in off/stand-by mode

Technical data on the appliance's power consumption in off/stand-by mode can be found at [www.smeg.com](http://www.smeg.com) under the page corresponding to the product in question.

## 1.4 Manufacturer liability

The manufacturer declines all liability for damage to persons or property caused by:

- Use of the appliance other than the one envisaged;
- Not having read the user manual;
- Tampering with any part of the appliance;
- Use of non-original spare parts;
- Not following the safety instructions.

## 1.5 Disposal



This appliance must be disposed of separately from other waste (Directive 2012/19/EU).

- The appliance does not contain substances in quantities sufficient to be considered hazardous to health and the environment, in accordance with current European directives.
- Old electrical appliances must not be disposed of together with household waste! To comply with current legislation, old appliances, on reaching the end of their useful lives, should be taken to a disposal facility where they can be sorted. The relevant local authorities or their waste disposal operators can provide further information.
- Take these packing materials to the appropriate recycling centre.

# Instructions



## Power voltage Danger of electrocution

- Disconnect the main power supply.
- Disconnect the power cable from the electrical system.



## Suffocation hazard due to plastic packaging:

- Do not leave the packaging or any part of it unattended.
- Do not let children play with the plastic bags.



## Electrical Shock Hazard

- Plug into a grounded 3 prong outlet.
- Do not remove earth prong.
- Do not use an adapter.
- Do not use an extension cord.
- Failure to follow these instructions can result in death, fire, or electrical shock.



## Improper use Electrical shock hazard

- Always disconnect the plug from the socket before cleaning the toaster, crumb tray and optional accessories.



## Hot appliance Burns Hazard

- Always leave the appliance and optional accessories to cool down before cleaning.



## Improper use Risk of damage to surfaces

- Do not use steam jets for cleaning the appliance.
- Do not use cleaning products containing chlorine, ammonia or bleach on steel parts or parts with metallic finishes (e.g. anodizing, nickel- or chromium-plating).
- Do not use abrasive or corrosive detergents (e.g. powder products, stain removers and metallic sponges).
- Do not use rough or abrasive materials or sharp metal scrapers.



## Hot appliance

- The bun warmer and sandwich rack will be hot during the toasting cycle. When removed from the toaster, take care not to burn yourself by touching the metal parts.



# Description

## 2 Product description (Fig. A - B)

- 1) Extra-wide slots with self-centering racks
- 2) Breadlift
- 3) Control panel
- 4) Crumb tray
- 5) Cable compartment (under base)
- 6) TSSR01 Sandwich racks (optional accessory suitable for TSF01 Toaster)
- 7) TSSR02 Sandwich racks (optional accessory suitable for TSF02 Toaster)
- 8) TSBW01 Bun Warmer (optional accessory suitable for TSF01 Toaster)
- 9) TSBW02 Bun Warmer (optional accessory suitable for TSF02 Toaster)
- 10) Defrost function button
- 11) Browning control knob
- 12) Browning indicator
- 13) Stop function button
- 14) Bagel function button
- 15) Reheat function

## 2.1 Control panel (Fig. B)

- Defrost function button (10 - Fig. B)

This function is useful when using frozen bread. During toasting the defrost button will light up to indicate that the cycle is activated.

- Browning control knob (11 - Fig. B)

This control is used to select one of the 6 different browning levels or the Reheat function. During toasting the central LED lights up to indicate that the toasting cycle is activated.

- Browning indicator (12 - Fig. B)

The Browning indicator shows the selected browning level or the selected Reheat function.

- Stop function button (13 - Fig. B)

The Stop button can be used to cancel or stop the toasting cycle at any time.

- Bagel function button (14 - Fig. B)

This feature will toast one side of a bagel or any other kind of bread, without toasting the other side. During toasting the Bagel button will light up to indicate that the function has been activated.

- Reheat function (15 - Fig. B)

This function is used to reheat cold toast or to continue a toasting cycle if the result is not satisfactory. During toasting the central LED lights up to indicate that the cycle is activated.



### 3 Use



The appliance can be used safely at both 50 Hz or 60 Hz without making any setting change.



#### Tips and suggestions

Your toaster has a 3-prong grounded plug. To reduce the risk of electrical shock, this plug will fit in an outlet only one way. If the plug does not fit in the outlet, contact a qualified electrician. Do not modify the plug in any way.

#### 3.1 Before first use

- 1) Remove all stickers and any packing or printed material that might have fallen inside during shipping or handling. Do not probe inside the toaster with a metal object.
- 2) Clean the outside of the toaster with a damp cloth.
- 3) Use the toaster for the first time without any bread in it.
- 4) Turn the browning control to the maximum position and press the breadlift down. In this way you will burn off any dust that has fallen into the toaster during production or transport.



During first use there may be some smoke and odors.



#### Tips and suggestions

- Remember that the type of bread you use will impact the toasting times. The fresher the bread you use, the longer it will take to toast. Different kinds of bread have different moisture content and will require different browning levels. For example, fruit breads generally toast much quicker, and freshly baked breads will take longer as they have a greater moisture content.
- The first batch of toast you make enables the heating elements to reach the correct toasting temperature. Please note that further batches of toast could take less time.

For best results:

- Toast only one type of bread at a time.
- Toast bread slices of the same thickness.
- Use bread slices no thicker than one inch.
- If you are using handcut bread, try to cut slices as evenly as possible. Uneven slices will toast unevenly.
- Be aware that if you use very thin or broken slices of bread, they will burn.



#### Warning

If the appliance is not connected to the mains, the breadlift does not lock.



# Use

## 3.2 Operation

If necessary, shorten the cord by wrapping it under the base (5 - Fig. A).

- 1) Plug in the toaster.
- 2) Insert the bread in the slot (Fig. C).
- 3) Remember that as bread is not normally square, you may need to turn the bread on its side to get a better fit and optimize the toasting surface area.
- 4) Choose the desired browning level (Browning levels 1 to 6, from light to dark) or the "Reheat function" (15 - Fig. B).
- 5) Push the lever down until it clicks to activate the toasting cycle (Fig. C).
- 6) If needed, select the additional functions Defrost (10 - Fig. B) or Bagel (14 - Fig. B) or the two combined.
- 7) The heating element is now activated. The bread will be centered in the breadlift automatically for toasting.
- 8) The toasted bread will pop up automatically when the toast is ready.
- 9) If the toast is not brown enough and requires just a little extra time, use the reheat button to extend the toasting time.

## 3.3 Special functions

### Canceling/stopping the toasting cycle

At any time, it is possible to cancel or stop the toasting cycle by pushing the button (13 - Fig. B).

### Defrost (10 - Fig. B)

This function gently defrosts frozen bread and toasts it to the selected browning level.

To activate it, insert the bread into the slot, select the desired browning level, press the breadlift down until it clicks, then push the defrost button, which will light up. Toasting time will be automatically increased to allow the bread to defrost and brown correctly. When the toast pops up automatically, the light of the defrost button will switch off.

### Bagel (14 - Fig. B)

This special function is ideal for toasting one side only, for bagels, flat bread, English muffins, baguettes, etc. To use the function, simply insert the bread into the slot with the side that you want toasted facing the outside. Select the desired browning level, press the breadlift down until it clicks, then push the Bagel function button, which will light up. When the bread is toasted, it will pop up automatically and the Bagel function light will switch off.

### Reheat (15 - Fig. B)

This function allows you to reheat cold toasts or to continue a toasting cycle if the result is not satisfactory. To activate it, insert the bread into the slot, select the Reheat function on the browning control knob and press the breadlift down until it clicks. The central light of the browning control knob will light up. When the toast is ready, it will pop up automatically and the light of the control knob will switch off.



Defrost or Reheat can be selected at the same time as the Bagel function.



### 3.4 Using optional accessories (6,7,8,9 - Fig. A)



Accessories may differ according to the model.

#### Sandwich racks (1-Fig. D)

The sandwich racks are ideal for toasting filled sandwiches, or for easier handling of smaller items such as bagels.

- TSSR01 model suitable for TSF01 Toaster (6 - Fig. A)
- TSSR02 model suitable for TSF02 Toaster (7 - Fig. A).



#### Tips and suggestions

- Lightly butter the outside of the bread, this prevents burning and helps with the warming of the filling. Do not butter the inside of the sandwich.
- For best results use thinly sliced ingredients and finely grated cheese.
- For best results use cold meat (ham, turkey, etc.) at room temperature, not straight from the refrigerator.
- Do not overfill the sandwich.
- If using a low browning setting, the filling might not heat through correctly. In this case, at the end of the toasting cycle, leave the toast inside the toasting slot for longer, or extend the time by using the reheat button.

#### How to use (1 - Fig. D):

- 1) Open the rack with the handles.
- 2) Place the sandwich inside the rack.
- 3) Close the sandwich rack handles together to grip the sandwich in the middle of the racks.
- 4) Insert the sandwich rack into the slot and select a browning level. If a little more browning is required, you can use the reheat button to extend the toasting time.
- 5) Push the breadlift down until it clicks to activate the toasting cycle.
- 6) When the toasting cycle has ended remove the sandwich rack from the toaster.

#### Bun Warmer (2 - Fig. D)

The bun warmer is used to warm small bread rolls, flat bread or pastries.

- TSBW01 model suitable for TSF01 Toaster (8 - Fig. A)
- TSBW02 model suitable for TSF02 Toaster (9 - Fig. A).

#### How to use (2 - Fig. D):

- 1) Place the bun warmer on top of the toaster, making sure the wire feet on the bottom of the warmer fit into the toaster slots.
- 2) Place small bread rolls, flat bread or pastries on top of the warmer and set the browning level to '1' (no higher).
- 3) Lower the breadlift until it clicks to activate the toasting cycle.



# Cleaning and maintenance/What to do if...

## 4 Cleaning and maintenance

### 4.1 Cleaning the surfaces

To keep the surfaces in good condition, clean regularly after use. Let them cool first.

Never use products that contain abrasives or chlorine-based acids.

Pour the product onto a damp cloth and wipe the surface, then wipe over thoroughly and dry with a soft cloth or a microfiber cloth



#### Tips and suggestions

If grease or oil splatters on the toaster, wipe it off immediately using a clean, damp cotton cloth.

Any other servicing should be performed by an authorized service representative.

### 4.2 Food stains or residues

Do not use metallic sponges or sharp scrapers as they will damage the surfaces.

Use ordinary non-abrasive products with the aid of wooden or plastic utensils if necessary. Wipe over thoroughly and dry with a soft cloth or a microfiber cloth.

### 4.3 Cleaning the crumb tray (Fig. E)

- 1) Push the Crumb Tray (4 - Fig. A) to unlock it, then pull to slide it out and empty it. The Crumb Tray should be emptied after each use.



#### Tips and suggestions

The Crumb Tray is hand-washable. Always dry the tray thoroughly before putting it back in the toaster.

- 2) Put the Crumb Tray back in the toaster. Press it in firmly until it clicks into position. Do not use the toaster without the Crumb Tray in the proper position.
- 3) Do not use any toaster cover.

### 4.4 Cleaning the optional sandwich rack and bun warmer

Wash the sandwich rack and bun warmer by hand in warm soapy water. After washing, rinse them and dry them thoroughly with a soft cloth.

### What to do if...

If your toaster should fail to operate, check the following:

- Check that the toaster is plugged into a grounded 3-prong electrical outlet. If it is, unplug the toaster.
- Plug in the toaster.
- If the toaster still does not work, check the household fuse or circuit breaker.

If the problem cannot be solved:

- See the Smeg Warranty and Service sections.



**MANUALE D'USO**

TOSTAPANE 2 E 4 FETTE

**INSTRUCTION MANUAL**

2 SLICE AND 4 SLICE TOASTER

**MANUEL D'UTILISATION**

GRILLE-PAIN 2 ET 4 TRANCHES

**BEDIENUNGSHANDBUCH**

2- UND 4-SCHEIBEN-TOASTER

**GEBRUIKSAANWIJZING**

BROODROOSTER 2 EN 4 BOTERHAMMEN

**MANUAL DE USO**

TOSTADORA DE 2 Y 4 REBANADAS

**MANUAL DE UTILIZAÇÃO**

TOSTADEIRA DE 2 E 4 FATIAS

**BRUKSANVISNING**

BRÖDROST 2 OCH 4 SKIVOR

**РУКОВОДСТВО ПО ЭКСПЛУАТАЦИИ**

ТОСТЕР НА 2 И 4 ЛОМТИКА

**BRUGERVEJLEDNING**

BRØDRISTER TIL 2 OG 4 SKIVER

**INSTRUKCJA OBSŁUGI**

TOSTER NA 2 LUB 4 KROMKI

**KÄYTTÖOPAS**

LEIVÄNPAAHDIN 2 JA 4 VIIPALETTA

**BRUKSANVISNING**

BRØDRISTER 2 OG 4 SKIVER

**دليل التعليمات**

محمصة ثنائية القطعة ورباعية القطعة

IT

EN

FR

DE

NL

ES

PT

SV

RU

DA

PL

FI

NO

AR

 **smeg**

**Informazioni importanti per l'utente, Important information for the user, Informations importantes pour l'utilisateur, Wichtige Informationen für den Benutzer, Belangrijke informatie voor de gebruiker, Información importante para el usuario, Informações importantes para o utilizador, Viktig information för användaren, Важная информация для пользователя, Vigtig information til brugeren, Ważne informacje dla użytkownika, Tärkeitä tietoja käyttäjälle, Viktig informasjon for brukere, معلومات هامة للمستخدم**



**Avvertenze / Recommendations / Avertissements / Hinweise / Waarschuwingen / Advertencias / Advertências / Varningar / Меры предосторожности / Advarslar / Ostrzeżenia / Varoitukset / Advarslar / تحذيرات**



**Descrizione / Description / Description / Beschreibung / Beschrijving / Descripción / Descrição / Beskrivning / Описание / Beskrivelse / Opis / Kuvaus / Bekrivelse / الوصف**



**Uso / Use / Utilisation / Gebrauch / Gebruik / Uso / Utilização / Användning / Использование / Anvendelse / Użytkowanie / Käyttö / Bruk / الإستعمال**



**Pulizia e manutenzione / Cleaning and care / Nettoyage et entretien / Reinigung und Wartung / Reiniging en onderhoud / Limpieza y mantenimiento / Limpeza e manutenção / Rengöring och underhåll / Чистка и техническое обслуживание / Rengøring og vedligeholdelse / Czyszczenie i konserwacja / Puhdistus ja hoito / Rengjøring og vedlikehold / التنظيف و الصيانة**



**Avvertenza di sicurezza / Safety instructions / Consignes de sécurité / Sicherheitshinweise / Veiligheidswaarschuwingen / Advertencia de seguridad / Advertências de segurança / Säkerhetsvarning / Предупреждение о безопасности / Sikkerhedsanvisninger / Ostrzeżenie dotyczące bezpieczeństwa / Turvallisuu teen liittyvät varoitukset / Sikkerhetsadvarslar / تحذير للسلامة**



**Informazione / Information / Information / Information / Informatie / Información / Informação / Information / Информация / Information / Informacja / Tietoja / Informasjon / معلومات**



**Suggerimento / Advice / Conseil / Empfehlungen / Aanbeveling / Sugerencia / Sugestões / Råd / Рекомендация / Forslag / Porada / Neuvo / Forslag / اقتراحات**

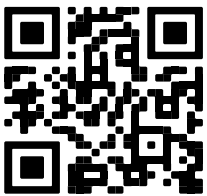

**MY SMEG  
ASSISTANT**

Scansiona il QR code per un accesso rapido al portale My Smeg Assistant  
Scan the QR code for quick access to the My Smeg Assistant portal  
Scannez le code QR pour un accès rapide au portail My SMEG Assistant  
Für den schnellen Zugriff auf das Portal MySmegAssistant scannen Sie einfach den QR-Code  
Scan de QR-code voor de Handleiding voor Snelle Installatie en Onderhoud  
Escanee el código QR para acceder rápidamente al portal My Smeg Assistant  
Leia o Código QR para ter acesso rápido ao portal My Smeg Assistant  
Skanna QR-koden för att snabbt öppna portalen My Smeg Assistant  
Отсканируйте QR-код для быстрого доступа к portalу My Smeg Assistant  
Scan QR-koden for hurtigt at få adgang til portalen My Smeg Assistant  
Zeskanuj kod QR, aby uzyskać szybki dostęp do portalu My Smeg Assistant  
Skannaa QR-koodi, jonka avulla pääset nopeasti My Smeg Assistant -portaaliin  
Skann QR-koden for hurtig tilgang til portalen My Smeg Assistant

اسمح رمز الاستجابة السريعة من أجل الوصول بسرعة إلى بوابة الدعم My Smeg Assistant

Gentile Cliente, La ringraziamo vivamente per il Suo acquisto. I nostri prodotti sono unici perché uniscono una spiccata ricerca estetica alla progettazione tecnica innovativa. Essi sono coordinati con altri prodotti in gamma e possono costituire elementi d'arredo e di design. Augurandole di apprezzare appieno le funzionalità del Suo elettrodomestico, Le porgiamo i nostri più cordiali saluti.

Dear Customer, Thank you for purchasing one of our appliances. Our products are unique because they combine iconic style with innovative technical solutions. They match perfectly with other products in our range and work equally well as a standalone design objects in your kitchen. We hope you enjoy using your new appliance! Best regards.

Cher client, merci beaucoup pour votre achat. Nos produits sont uniques car ils combinent une forte recherche esthétique avec une conception technique innovante. Ils sont coordonnés avec d'autres produits de la gamme et peuvent constituer des éléments d'ameublement et de design. En espérant que vous pourrez apprécier pleinement votre nouvel appareil électroménager, nous vous adressons nos meilleures salutations.

Sehr geehrter Kunde, wir danken Ihnen herzlich für den Kauf. Unsere Produkte sind einzigartig, da sich in ihnen eine gewissenhafte Designforschung und eine innovative technische Planung vereinen. Sie sind mit anderen Produkten des Sortiments kombinierbar und stellen ausgefallene Einrichtungs- und Designgegenstände dar. Wir hoffen, dass Sie Ihr neues Haushaltsgerät voll und ganz schätzen werden und verbleiben mit freundlichen Grüßen.

Beste klant, hartelijk dank voor uw aankoop. Onze producten zijn uniek omdat ze esthetiek combineren met innovatief technisch ontwerp. De producten zijn uitstekend te combineren andere producten van het assortiment en kunnen worden gebruikt als meubel- en designelementen. We hopen dat u volop van uw nieuwe huishoudelijke apparaat zult genieten. Met vriendelijke groet

Estimado cliente, le damos las gracias por su compra. Nuestros productos son únicos porque combinan una notable búsqueda estética con un diseño técnico innovador. Se combinan con otros productos de la gama y se pueden utilizar como elementos de decoración y diseño. Le deseamos que pueda apreciar plenamente su nuevo electrodoméstico. Le enviamos nuestros saludos más cordiales.

Prezado cliente, Muito obrigado pela sua compra. Os nossos produtos são únicos porque combinam uma forte busca estética com um desenho técnico inovador. São coordenados com outros produtos da linha e podem constituir elementos de decoração e design. Esperando que possa desfrutar totalmente das funcionalidades do seu eletrodoméstico, enviamos-lhe os nossos melhores cumprimentos.

Bäste kund, vi vill tacka dig för ditt köp. Våra produkter är unika eftersom de kombinerar ett estetiskt nytänkande med innovativ teknik. Våra produkter passar med de andra i samma serie och kan användas som föremål inom heminredningen för att ge en särskild känsla av stil i ditt hem. Vi hoppas att du till fullo kommer att uppskatta funktionerna hos din hushållsmaskin. Med bästa hälsningar.

Уважаемый покупатель! Благодарим Вас за покупку. Наши изделия уникальны, поскольку они сочетают в себе великолепный дизайн и передовые технические решения. Кроме того, они комбинируются с другими изделиями из этой линейки и могут стать стильными элементами интерьера и дизайна. Надеемся, что Вы в полной мере оцените функциональные возможности Вашего бытового прибора. С наилучшими пожеланиями.

Kære Kunde, mange tak for dit køb. Vores produkter er unikke, da de forener æstetisk research og innovativt teknisk design. De passer perfekt sammen med de andre produkter i serien, og kan stå som et enkeltstående møbel af design. Vi håber, at du vil værdsætte din hårde hvidevares funktionalitet, og sender de bedste hilsener.

Szanowny Kliencie, Dziękujemy za Twój zakup. Nasze produkty są wyjątkowe, ponieważ łączą intensywne badania estetyczne z innowacyjnym projektem technicznym. Są one skoordynowane z innymi produktami z asortymentu i mogą stanowić elementy wyposażenia i wystrój. Mamy nadzieję, że będą Państwu mogli w pełni korzystać z funkcjonalności tego urządzenia. Serdecznie pozdrawiamy.

Arvoisa Asiakas, kiitämme sinua hankintasi johdosta. Tuotteemme ovat ainutlaatuisia, koska niissä yhdistyvät esteettisyys ja innovatiivinen tekninen suunnittelu. Ne sopivat yhteen muiden valikoimaan kuuluvien tuotteiden kanssa toimien samalla sisustus- ja design-tuotteina. Toivomme, että voit nauttia täysin siemauksin kodinkoneesi toiminnoista. Sydämellisin terveisin.

Kjære kunde. Vi takker for at dere valgte å kjøpe et av våre produkter. Våre produkter er unike fordi de forener søken etter estetikk med en nyskapende teknisk design. De koordineres med andre produkter i vårt sortiment og kan ha funksjon som både møbel- og designvare. Vi håper du får fullt utbytte av ditt husholdningsapparat, og sender deg våre beste hilsener.

تحتفظ جهة التصنيع بحقها في إجراء أية تغييرات تراها ضرورية لتحسين منتجاتها دون إخطار مسبق. لذا، تعتبر الرسوم التوضيحية والأوصاف الواردة في هذا الدليل غير ملزمة ولكنها إرشادية فقط.

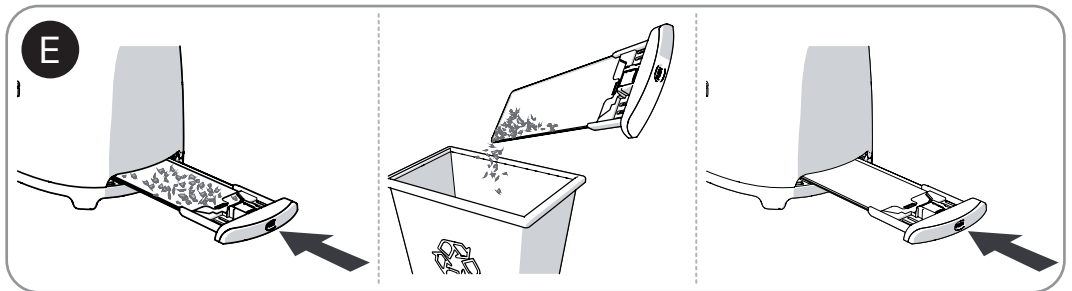
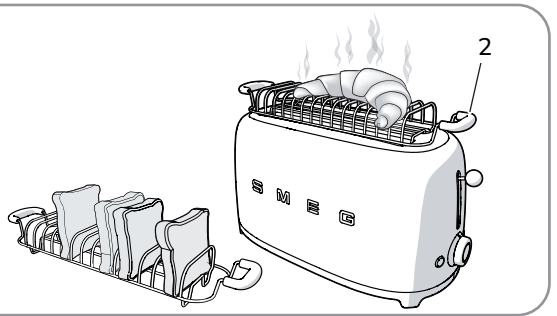
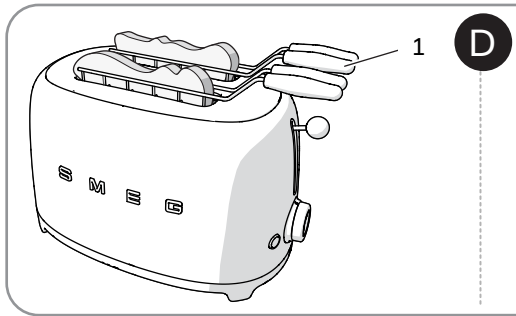
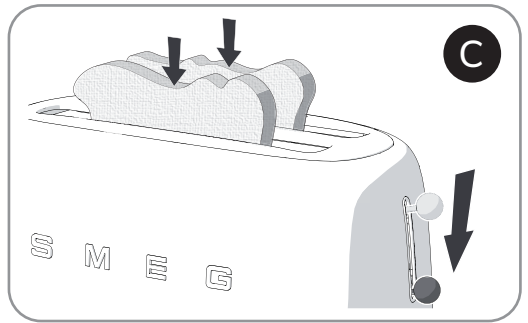
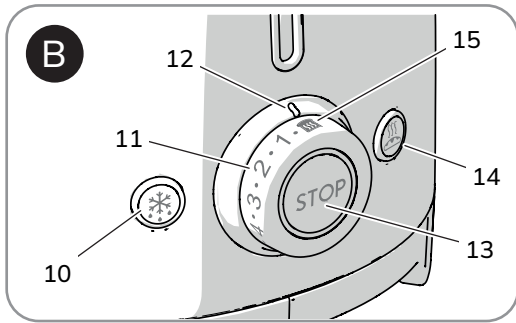
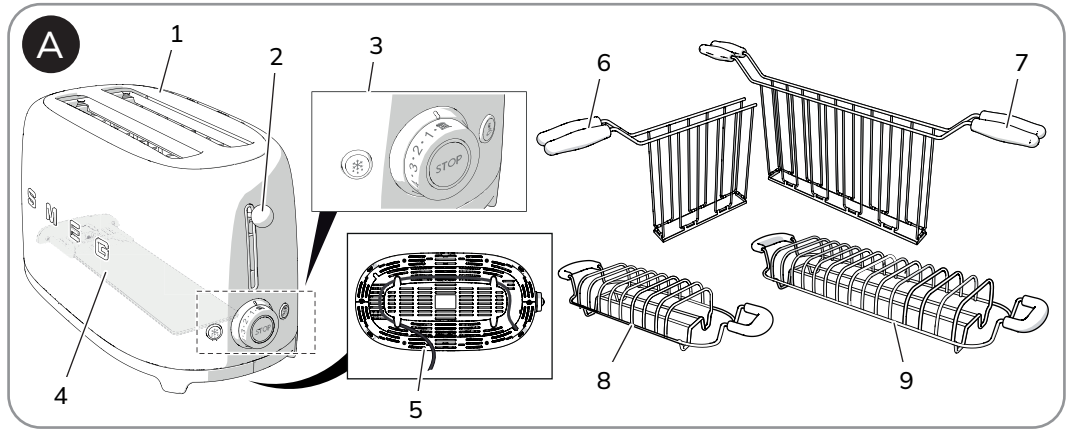

Il costruttore si riserva di apportare senza preavviso tutte le modifiche che riterrà utili al miglioramento dei propri prodotti. Le illustrazioni e le descrizioni contenute in questo manuale non sono quindi impegnative ed hanno solo valore indicativo.

The manufacturer reserves the right to make any changes deemed necessary for the improvement of its products without prior notice. The illustrations and descriptions contained in this manual are therefore not binding and are merely indicative.

Le fabricant se réserve la faculté d'apporter, sans préavis, toutes les modifications qu'il jugera utiles pour l'amélioration de ses produits. Les illustrations et les descriptions figurant dans ce manuel ne sont pas contraignantes et n'ont qu'une valeur indicative.

Der Hersteller behält sich vor, ohne vorherige Benachrichtigung alle Änderungen vorzunehmen, die er zur Verbesserung seiner Produkte für nützlich erachtet. Die in diesem Handbuch enthaltenen Illustrationen und Beschreibungen sind daher unverbindlich und dienen nur zur Veranschaulichung.

De fabrikant behoudt zich het recht voor zonder waarschuwing alle wijzigingen aan te brengen die hij nodig acht om zijn producten te verbeteren. De afbeeldingen en de beschrijvingen die aanwezig zijn in deze handleiding zijn niet bindend, en hebben enkel een aanduidende waarde.

El fabricante se reserva el derecho a aportar sin aviso previo todas las modificaciones que considere útiles para la mejora de sus propios productos. Las ilustraciones y las descripciones contenidas en este manual no son vinculantes y tienen solo valor indicativo.

O fabricante reserva-se o direito de efetuar, sem aviso prévio, qualquer modificação que vise o melhoramento dos respetivos produtos. As ilustrações e descrições contidas neste manual não são, por isso, vinculativas e possuem apenas valor indicativo.

Tillverkaren förbehåller sig rätten att genomföra alla de ändringar som anses nödvändiga för att förbättra de egna produkterna utan att meddela detta i förväg. De illustrationer och beskrivningar som finns i aktuell manual är därmed inte bindande utan endast indikativa.

Для улучшения выпускаемой продукции изготовитель оставляет за собой право вносить без предварительного предупреждения любые изменения, которые он сочтет целесообразными. Рисунки и описания, содержащиеся в данном руководстве, не являются обязывающими и носят ознакомительный характер.

Fabrikanten forbeholder sig retten til, uden varsel, at udføre alle de ændringer, der vurderes nyttige for at forbedre egne produkter. Tegningerne og beskrivelserne i denne manual er derfor kun vejledende og ikke bindende.

Producent zastrzega sobie prawo do nanoszenia, bez uprzedniego powiadomienia, wszelkich zmian, które uzna za stosowne w celu ulepszenia swoich produktów. Rysunki i opisy zawarte w niniejszej instrukcji nie są zobowiązujące i mają jedynie charakter orientacyjny.

Valmistaja pidättää itsellään oikeuden tehdä ohjeisiin mielestään tarpeellisia muutoksia ilman ennakoilmoitusta. Tässä oppaassa olevat kuvat ja piirrokset eivät näin ollen ole sitovia, vaan ne annetaan vain viitteellisessä mielessä.

Produsenten forbeholder seg rett til å foreta endringer på sine produkter grunnet tekniske fremskritt, uten forutgående varsel. Illustrasjonene og beskrivelsene i denne bruksanvisningen er derfor ikke bindende og skal kun betraktes som retningsgivende.

عملينا العزيز، شكرا لك على شراء أحد أجهزتنا. تعد منتجاتنا فريدة لأنها تجمع بين الأسلوب المميز والحلول التقنية المبتكرة. وهي تتناسب تماما مع المنتجات الأخرى في مجموعتنا وتعمل بنفس القدر كتصميمات قائمة بذاتها في مطبخك. نأمل أن تستمتع باستخدام هذا الجهاز الجديد! وتفضلوا بقبول وافر الاحترام والتقدير.