

MANUALE D'USO
SBATTITORE ELETTRICO

IT

USER MANUAL
HAND MIXER

EN

MANUEL DE L'UTILISATEUR
BATTEUR

FR

GEBRAUCHSANLEITUNG
HANDRÜHRGERÄT

DE

GEBRUIKSAANWIJZING
MIXER

NL

MANUAL DE USO
BATIDORA

ES

MANUAL DE USO
BATEDEIRA

PT

BRUKSANVISNING
MIXER

SV

РУКОВОДСТВО ПО ЭКСПЛУАТАЦИИ
МИКСЕР

RU

BRUGSANVISNING
HÅNDMIKSER

DA

INSTRUKCJA OBSŁUGI
MIKSER

PL

KÄYTTÖOHJE
SÄHKÖVATKAIN

FI

BRUKSANVISNING
VISP

NO

كتيب الاستخدام
مضرب

AR

smeg

Consigliamo di leggere attentamente questo manuale, che riporta tutte le indicazioni per mantenere inalterate le qualità estetiche e funzionali dell'apparecchio acquistato.
Per ulteriori informazioni sul prodotto: www.smeg.com

We advise you to read this manual carefully, as it contains all the instructions for managing the appliance's aesthetic and functional qualities.
For further information on the product: www.smeg.com

Nous conseillons de lire attentivement ce manuel, qui comprend toutes les indications pour maintenir inaltérées les qualités esthétiques et fonctionnelles de l'appareil acheté.
Pour obtenir des informations supplémentaires sur le produit : www.smeg.com

Wir empfehlen, diese Bedienungsanleitung, die sämtliche Anweisungen enthält, um das Aussehen und die Funktionsfähigkeit des Geräts zu erhalten, sorgfältig zu lesen.
Für weitere Informationen über das Produkt wird auf www.smeg.com verwiesen

We adviseren om deze handleiding aandachtig door te lezen. Ze bevat aanwijzingen die nodig zijn om de esthetische en functionele eigenschappen van het gekochte apparaat intact te houden.
Bezoek voor meer informatie over het product: www.smeg.com

Aconsejamos leer atentamente este manual que contienen todas las indicaciones para mantener inalterada la calidad estética y funcional del aparato adquirido.
Más información sobre el producto en: www.smeg.com

Aconselhamos que leia atentamente este manual, que refere todas as indicações para manter inalteradas as qualidades estéticas e funcionais do aparelho comprado.
Para mais informações sobre o produto: www.smeg.com

Vi rekommenderar att ni noga läser denna handbok som anger alla de nödvändiga anvisningarna för att bibehålla den inköpta apparatens utseende och funktioner.
För mer information om produkten: www.smeg.com

Мы рекомендуем вам внимательно прочитать данное руководство, в котором приводятся все указания, необходимые для поддержания неизменными эстетических и функциональных свойств приобретенного прибора.
Дополнительную информацию об изделии можно получить на сайте: www.smeg.com

Vi anbefaler, at du nøje læser denne vejledning, som indeholder alle anvisninger til at holde det købte apparat i perfekt funktionsmæssig og æstetisk stand.
For yderligere informationer om produktet: www.smeg.com

Zalecamy uważnie przeczytanie niniejszej instrukcji, która zawiera wszystkie wskazówki dla utrzymania jakości estetyki i funkcjonalności zakupionego urządzenia.
Dalsze informacje dotyczące produktu znajdują się na stronie: www.smeg.com

Lue tämä käyttöopas huolellisesti. Ohjeita noudattamalla taataan laitteen oikeaoppinen ylläpito ja sen ominaisuuksien säilyvyys.
Tuotteeseen liittyvät lisätiedot löytyvät osoitteesta www.smeg.com

Vi anbefaler at du leser denne brukerveiledningen grundig, da den inneholder alle indikasjonjer for å bevare de estetiske og funksjonelle kvalitetene til produktet du har kjønt.
For ytterligere informasjon om produktet: www.smeg.com

ننصح بقراءة هذا الكتيب بعناية حيث يضم جميع التعليمات التي تضمن الحفاظ على الخصائص الجمالية والوظيفية للمنتج الذي قمت بشرائه.
للمزيد من المعلومات عن المنتج يرجى زيارة www.smeg.com

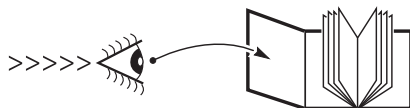

"A"

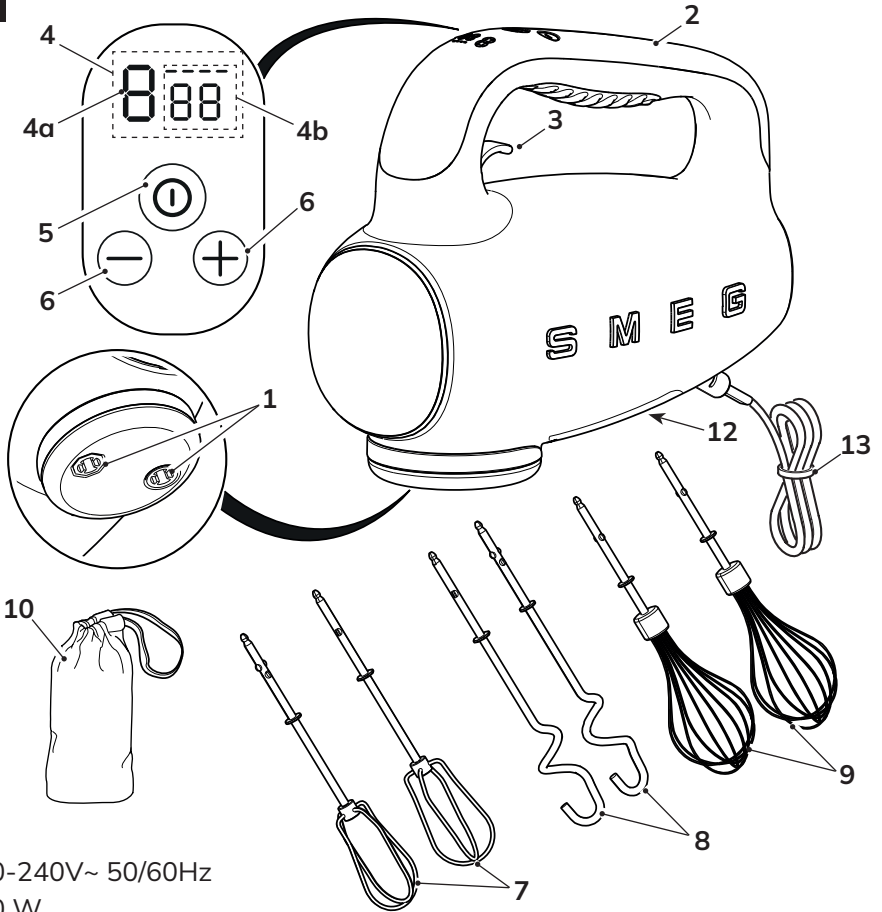

220-240V~ 50/60Hz
250 W

"B"

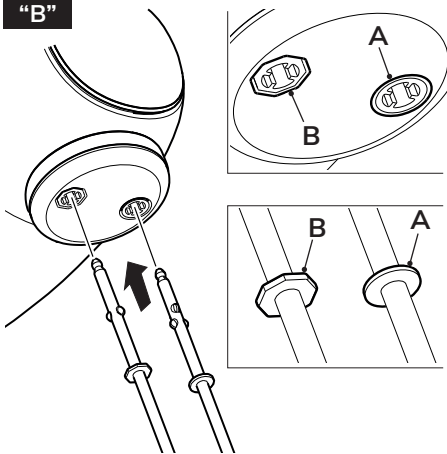

"C"

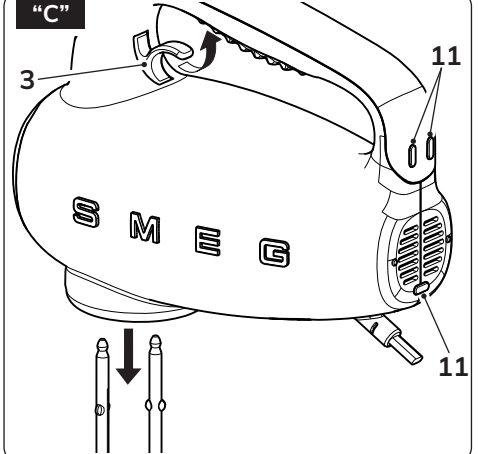

Informazioni importanti per l'utente / Important information for the user
Informations importantes pour l'utilisateur / Wichtige Informationen für den Benutzer
Belangrijke informatie voor de gebruiker / Información importante para el usuario
Informações importantes para o utilizador / Viktig information för användaren
Важная информация для пользователя / Viktig information til brugeren
Ważne informacje dla użytkownika / Tärkeät tiedot käyttäjälle
Viktig informasjon for brukere / معلومات عامة للمستخدم

⚠ Avvertenze / Instructions / Avertissements / Hinweise / Waarschuwingen / Advertencias / Advertências / Varningar /
Меры предосторожности / Advarsler / Ostrzeżenia / Varoitusket / Advarsler / تحذيرات

Informazioni generali su questo manuale d'uso, di sicurezza e per lo smaltimento finale / General information on this user manual, on safety and final disposal / Informations générales sur ce manuel d'utilisation, sur la sécurité et sur l'élimination définitive de l'appareil / Allgemeine Informationen zu dieser Gebrauchsanleitung, zur Sicherheit und die endgültige Entsorgung / Algemene informatie over deze handleiding, veiligheidsinstructies en uiteindelijke verwerking / Información general del manual relativa al uso, la seguridad y la eliminación final / Informações gerais sobre este manual do utilizador, segurança e para a eliminação final / Allmän information om denna bruksanvisning, om säkerhet och för slutligt bortskaffande / Общая информация о данном руководстве по эксплуатации, безопасности и окончательной утилизации / Generelle oplysninger om denne betjenings- og sikkerhedsvejledning samt endelig bortskaffelse / Ogólne informacje dotyczące użytkowania, bezpieczeństwa i utylizacji / Käyttöohjetta, turvallisuutta ja käytöstä poistoa koskevat yleisetiedot / Generell informasjon om denne brukerveiledningen, sikkerhet og endelig kassering av produktet / معلومات عامة عن دليل استخدام هذا الجهاز وسلامة استخدامه وكيفية التخلص عن الجهاز بشكل نهائي

📖 Descrizione / Description / Description / Beschreibung / Beschrijving / Descripción / Descrição / Beskrivning / Описание /
Beskrivelse / Opis / Kuvaus / Beksrivelse / الوصف

Descrizione dell'apparecchio / Appliance description / Description de l'appareil / Beschreibung des Geräts / Omschrijving van het apparaat / Descripción del aparato / Descrição do aparelho / Beskrivning av apparaten / Описание прибора / Beskrivelse af apparatet / Opis urządzenia / Laitteen kuvaus / Beskrivelse av apparatet / وصف الجهاز

👉 Uso / Use / Utilisation / Gebrauch / Gebruik / Uso / Utilização / Användning / Использование / Anvendelse / Użytkowanie /
Käyttö / Bruk / الاستعمال

Informazioni sull'uso dell'apparecchio / Information on using your appliance / Informations sur l'utilisation de l'appareil / Informationen zum Gebrauch des Geräts / Informatie over het gebruik van het apparaat / Información sobre el uso del aparato / Informações sobre a utilização do aparelho / Information om användning av apparaten / Информация об использовании прибора / Oplysninger om korrekt rengøring og vedligeholdelse af apparatet / Informacje dotyczące użytkowania urządzenia / Laitteistoa koskevat käyttöohjeet / Informasjon om bruken av apparatet / معلومات عن استخدام الجهاز

🧹 Pulizia e manutenzione / Cleaning and care / Nettoyage et entretien / Reinigung und Wartung /
Reiniging en onderhoud / Limpieza y mantenimiento / Limpeza e manutenção / Rengöring och underhåll / Чистка и
техническое обслуживание / Rengøring og vedligeholdelse / Czyszczenie i konserwacja /
Puhdistus ja hoito / Rengjøring og vedlikehold / التنظيف والصيانة

Informazioni per la corretta pulizia e manutenzione dell'apparecchio / Information for proper cleaning and maintenance of the appliance / Informations pour un nettoyage et un entretien corrects de l'appareil / Informationen zur ordnungsgemäßen Reinigung und Wartung des Geräts / Informatie voor de juiste wijze van reiniging en onderhoud van het apparaat / Información sobre la limpieza y el mantenimiento correctos del aparato / Informações para a limpeza e manutenção corretas do aparelho / Information för korrekt rengöring och underhåll av apparaten / Информация по корректной очистке и техобслуживанию прибора / Oplysninger om korrekt rengøring og vedligeholdelse af apparatet / Informacje dotyczące prawidłowego czyszczenia i konserwacji urządzenia / Laitteiston oikeaa puhdistusta ja huoltoa koskevat tiedot / Informasjon for korrekt rengjøring og vedlikehold av apparatet / معلومات لتنظيف وصيانة الجهاز بشكل صحيح

⚠ Avvertenza di sicurezza / Safety instructions / Consignes de sécurité / Sicherheitshinweise /
Veiligheidswaarschuwingen / Advertencia de seguridad / Advertências de segurança / Säkerhetsvarning /
Предупреждение о безопасности / Sikkerhedsanvisninger / Ostrzeżenie dotyczące bezpieczeństwa /
Turvallisuuteen liittyvät varoitukset / Sikkerhetsadvarsler / تحذير للسلامة

i Informazione / Information / Information / Information / Informatie / Información / Informação / Information /
Информация / Information / Informacja / Tietoa / Informasjon / معلومات

📝 Suggerimento / Advice / Conseil / Empfehlungen / Aanbeveling / Sugerencia / Sugestões / Råd /
Рекомендация / Forslag / Porada / Neuvo / Forslag / اقتراحات

Il costruttore si riserva di apportare senza preavviso tutte le modifiche che riterrà utili al miglioramento dei propri prodotti. Le illustrazioni e le descrizioni contenute in questo manuale non sono quindi impegnative ed hanno solo valore indicativo.

The manufacturer reserves the right to make any changes deemed useful for the improvement of its products without prior notice. The illustrations and descriptions contained in this manual are therefore not binding and are merely indicative.

Le fabricant se réserve la faculté d'apporter, sans préavis, toutes les modifications qu'il jugera utiles pour l'amélioration de ses produits. Les illustrations et les descriptions figurant dans ce manuel ne sont pas contraignantes et n'ont qu'une valeur indicative.

Der Hersteller behält sich vor, ohne vorherige Benachrichtigung alle Änderungen vorzunehmen, die er zur Verbesserung seiner Produkte für nützlich erachtet. Die in diesem Handbuch enthaltenen Illustrationen und Beschreibungen sind daher unverbindlich und dienen nur zur Veranschaulichung.

De fabrikant behoudt zich het recht voor zonder waarschuwing alle wijzigingen aan te brengen die hij nodig acht om zijn producten te verbeteren. De afbeeldingen en de beschrijvingen die aanwezig zijn in deze handleiding zijn niet bindend, en hebben enkel een aanduidende waarde.

El fabricante se reserva el derecho a aportar sin aviso previo todas las modificaciones que considere útiles para la mejora de sus propios productos. Las ilustraciones y las descripciones contenidas en este manual no comprometen, por tanto, al fabricante y tienen un valor meramente indicativo.

O fabricante reserva-se o direito de efetuar, sem aviso prévio, qualquer modificacão que vise o melhoramento dos respetivos produtos. As ilustracões e descriçoes contidas neste manual, não são, por isso, vinculativas e possuem apenas valor indicativo.

Tillverkaren förbehåller sig rätten att genomföra alla de ändringar som anses nödvändiga för att förbättra de egna produkterna utan att meddela detta i förväg. De illustrationer och beskrivningar som finns i denna bruksanvisning är vägledande och därmed inte bindande.

Производитель оставляет за собой право вносить без предупреждения все изменения, которые посчитает полезными для улучшения собственной продукции. Рисунки и описания, содержащиеся в данном Руководстве по эксплуатации, не имеют обязательств и имеют ознакомительный характер.

Producenten forbeholder sig retten til at foretage eventuelle ændringer, der anses for at være en forbedring af det oprindelige produkt, uden forudgående varsel. Illustrationer og beskrivelser i denne betjeningsvejledning er derfor ikke bindende og kun vejledende.

Producent zastrzega sobie prawo do nanoszenia, bez uprzedniego powiadomienia, wszelkich zmian, które uzna za przydatne w celu ulepszenia swoich produktów. Rysunki i opisy zawarte w niniejszej instrukcji nie są zobowiązujące i mają charakter poglądowy.

Valmistaja pidättää itsellään oikeuden tehdä ohjeisiin mielestään tarpeellisia muutoksia ilman ennakoilmoitusta. Tässä oppaassa olevat kuvat ja piirroukset eivät näin ollen ole sitovia, vaan ne annetaan vain viitteellisessä mielessä.

Produsenten forbeholder seg rett til endringer på sine produkter grunnet tekniske fremskritt, uten forutgående varsel.

Illustrasjonene og beskrivelsene i denne bruksanvisningen er derfor ikke bindende og skal kun betraktes som retningsgivende.

”تحفظ جهة التصنيع لنفسها بالحق في القيام بجميع التعديلات التي تراها مناسبة لتحسين منتجاتها دون إنذار مسبق، ولذلك، لا تعتبر الرسوم التوضيحية والأوصاف الواردة في هذا الدليل مُلزمة وإنما ذات قيمة إرشادية فقط”

Dear Customer,

Thank you very much for purchasing the Smeg Line Hand Mixer.

By choosing our product, you have opted for a solution in which aesthetics and innovative technical design offer unique objects, which become part of the furnishings.

In fact, a Smeg household appliance always co-ordinates perfectly with other products in the range and, at the same time, can become a design object for the kitchen.

We hope you fully appreciate the functionalities of your appliance.
Best regards.

SMEG S.p.A.

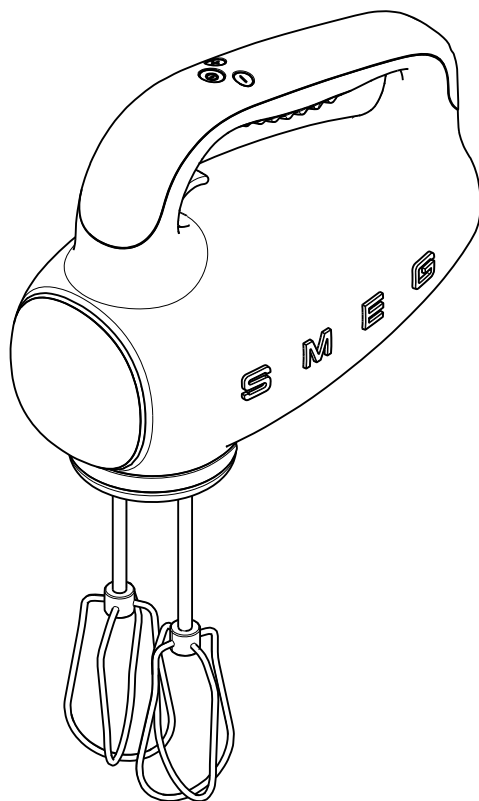

Model HMF01
Hand mixer



Recommendations

SAFETY

Essential safety recommendations.

Follow all safety instructions in order to be able to use the appliance safely:

- Do not touch the plug with wet hands.
- Make sure that the power outlet used is always freely accessible, so that it can be unplugged when necessary.
- Never pull the cable, it could be damaged.
- If the appliance should break down, do not attempt to repair it.

Switch the appliance off, remove the plug from the power outlet and contact the Technical After-sales centre.

- If the plug or power supply cable are damaged, have them replaced exclusively by the Technical After-sales centre, so as to prevent all risks.
- Do not immerse the appliance in water.
- Attention: disconnect the plug before cleaning.
- Do not allow the power supply cable to dangle over the edge of the table or other surface or to touch hot surfaces.
- Keep the packaging material (plastic bags) out of the reach of children.
- Appliances can be used by persons with reduced physical, sensory or mental capabilities or lack of experience and knowledge if they are closely supervised or instructed concerning use of the appliance in a safe way and if they understand the hazards involved.
- Children should be supervised to ensure that they do not play with the appliance.
- Do not place the appliance on or in proximity of electric or gas cookers, or in a heated oven.

- Verify that there are no foreign objects inside the appliance.
- With dense mixtures, to prevent overheating, do not use mixing with dough hooks continuously for more than 4 minutes. Leave to cool for 10 minutes before starting a new operation.
- Switch off the appliance and disconnect from supply before approaching parts that move when in use.
- Do not block the ventilation or heat dissipation slots.
- Immerse the whips in the bowl with the food before starting the appliance.

Connect the appliance

Make sure that the mains voltage and the frequency correspond with those indicated on the data plate on the bottom of the appliance. In the event of incompatibility between the outlet and the plug on the appliance, contact the Technical After-sales service for replacement.

- This appliance shall not be used by children.
Keep the appliance and its cord out of the reach of children.
- Children must not play with the appliance.
- Always disconnect the appliance from the supply if it is left unattended and before assembling, disassembling or cleaning.
- Switch off the appliance and disconnect from supply before changing accessories or approaching parts that move when in use.



Use compliant with destination

- Do not use the appliance for anything other than its intended use. The Hand Mixer is designed for mixing, kneading, whisking eggs or cream.
- The appliance is intended for household and similar use, such as:
 - in the kitchen area for the staff of shops, offices and other work environments;
 - in bed and breakfast and agritourism accommodation;
 - by guests at hotels and motels, and in residential environments.
- Other uses, in restaurants, bars and cafes for example, are improper.

Information on power consumption in off/stand-by mode

Technical data on the appliance's power consumption in off/stand-by mode can be found at www.smeg.com under the page corresponding to the product in question.

Manufacturer's liability

The manufacturer declines all liability for damage undergone by persons and objects due to:

- use of the appliance different from that envisioned;
- user manual has not been read;
- tampering of individual parts of the appliance;
- use of non-original spare parts;
- failure to comply with safety recommendations.



Keep these instructions carefully. Whenever the appliance is transferred to other persons, they must also be given these user instructions.

- These instructions can also be downloaded from Smeg website "www.smeg.com".

DISPOSAL

Electrical appliances must not be disposed of with household waste.



The appliances that have this symbol are subject to the European Directive 2012/19/EU. All discarded electric and electronic appliances must be disposed of separately from household waste, by taking them to relevant centres envisioned by the Country. By disposing of the discarded appliance correctly, damage to the environment and risks to health will be avoided. For further information regarding disposal of the discarded appliance, contact the Municipal



Description / Assembly / Commands

Administration, the Disposal dept. or the shop where the appliance was purchased.

DESCRIPTION OF THE APPLIANCE (Fig.A)

- 1 Accessory slots
- 2 Handle
- 3 Accessory release trigger
- 4 Speed and timer display
- 5 Start/Stop button
- 6 Speed adjustment buttons
- 7 Optimus beaters
- 8 Dough hooks
- 9 Wire beaters
- 10 Accessory bag
- 11 Feet
- 12 Identification plate
- 13 Cable winding clamp

IDENTIFICATION PLATE (12)

The identification plate states the technical data, the serial number and marking. The identification plate must never be removed.

BEFORE COMMISSIONING

- Unpack the appliance carefully and remove all packaging materials and any labels and stickers.
- Clean the motor base using a damp cloth.

Wash all components and dry thoroughly (see paragraph "Cleaning and Maintenance").



Before use, check that all components are integral.

ASSEMBLY OF COMPONENTS (Fig. B)

- Beaters and dough hooks must be inserted into the correct side, and are not interchangeable.
- Insert beater/dough hook with a **round**

ring (A) into the **round** slot (A).

- Insert beater/dough hook with **octagonal** ring (B) into the **octagonal** slot (B).



Do not use two accessories of different type together.

DESCRIPTION OF CONTROLS AND ACCESSORIES

The appliance is equipped with 3 buttons and a time and speed display.

Display (4)	
(4a)	(4b)
	----- Running timer in minutes
Selected speed	 Running timer in seconds

Buttons			
(5)	 ON - OFF Key		
(6)	<table border="1" style="width: 100%;"> <tr> <td style="text-align: center;"> Decrease speed </td> <td style="text-align: center;"> Increase speed/ Turbo function (keep pressed) </td> </tr> </table>	 Decrease speed	 Increase speed/ Turbo function (keep pressed)
 Decrease speed	 Increase speed/ Turbo function (keep pressed)		

Optimus beaters (7)

- Use this accessory for semi-hard doughs, medium-consistency creams, chocolate based doughs, pastry doughs, cakes and biscuits doughs, etc.
- Always use both beaters.



Dough hooks (8)

- Use this accessory for thick doughs, such as bread's and pizza's dough, egg pasta, etc.
- Always use both dough hooks.

Wire beaters (9)

- Use this accessory for creams with little consistency, sauces, mayonnaise, to beat cream, eggs, liquids, egg whites, etc.
- Always use both beaters.



Make sure that the bowl used is sufficiently large and high, as well as positioned on a stable surface.

USE (Fig. A)

- Insert the plug into the power outlet, display (4) off.
- Press the button to activate the **Stand-by mode**: the display (4a) shows 0 and the display (4b) shows 00, all of them flashing.



After 30 seconds of non-use, the display turns off.

- From **Stand-by mode** press the buttons / to start the motor and increase or decrease the speed, display (4b) will count up from 01 seconds to 59 seconds while the display (4a) shows the selected speed.
- After 1 minute of operation the display (4b) return to 0 and the first segment of the minutes running line light up to indicate that 1 minute is passed. The same for second minute and so up to 4 minutes and 59 seconds. After this time:
 - The motor automatically stops.
 - Display (4a) shows 0.
 - Display (4b) shows 4m59s blinking.

- When motor is running, press button to return in **Stand-by mode**.
- Pressing the button a second time turns the mixer off.



Smooth Start system

At the start of the appliance, speed increases progressively until the set speed is reached. This prevents the appliance and the tools from damaging and the ingredients from escaping from the container used.

Turbo function

- Keeping pressed button for 1 second will be activated **TURBO function**: display (4a) will show 9 number, display (4b) will continue the seconds count up. The motor speed will be the maximum allowed.
- After releasing the button the motor speed come back to original set one shown on display (4a). The display (4b) continues the seconds count up.
- When motor is running, press button to return in **Stand-by mode**.



Hints and tips

ADVICES

- Activate the appliance at a low speed until the ingredients are mixed and then increase the speed according to the operation to be performed.
- Climatic conditions, seasonal temperature differences, temperature and consistency of the ingredients could affect the preparation time necessary as well as the results.
- For the best results with thick dough, work it with rotational movements and check that the liquid ingredients are at least 50% of the total dough.



To work thick dough, do not exceed a maximum of 500 g of flour and let the mixer cool for about 5 minutes before reusing. Switch it off as soon as you've got the right consistency.



Place the container to be used for the processing on a stable and flat surface.



During processing or when not in use, it is possible to position the appliance on the specific feet (11) (Fig.C).







To protect your handmixer it is fitted with a protection device which will stop the handmixer operating if overloaded. If activated, the flashing symbol  will appear on the display; switch off, unplug, wait 10 minutes and then plug back into the power supply.

RECOMMENDED SPEEDS

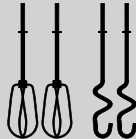

Please note that these are recommendations only and the speed you select may depend upon the bowl size, quantities, the ingredients you are mixing and personal preference.

Speed	Function	Accessory
Low 1 - 3	<u>Combine</u> Combining ingredients	
Low 1 - 3	<u>Knead</u> Kneading leavened doughs (bread, pizza)	
Medium 4 - 6	<u>Mixing</u> Mixing and beating liquid batters. Mixing compounds with eggs, butter such as cake mixes	
High 7 - 9	<u>Whipping and whisking</u> Whisking light or dense batters. Whipping cream, egg whites or sauce.	



To mix leavened dough, use only the dough hooks.



CLEANING AND MAINTENANCE (Fig. C)



Before carrying out any cleaning operation, ALWAYS disconnect the plug from the power outlet and allow the appliance to cool down. Never immerse the motor base (1) in water or other liquids.

The instruction manual contains appropriate instructions for cleaning and maintenance operations and operations recommended to the customer by the producer. Any other intervention must be performed by a representative of an authorised service centre.

- Pull the accessory release trigger (3) upwards and remove the accessories.
- Beaters, dough hooks, wire beaters accessories are dishwasher safe.
- Dry all parts of the appliance after cleaning.
- The motor base can be cleaned by first using a damp cloth and then a dry one. Do not use detergents or abrasive materials.

What To Do If.....

Problem	Possible causes	Solution
The motor works at a lower speed than the set one.	The dough in the bowl is too thick.	Remove part of it to lighten it.
	The plug has not been inserted.	Insert the plug.
The motor will not start.	The product has not been activated.	Activate the product by pressing the ON/OFF button.
	The motor is damaged.	Contact the service centre.
The whisks stop rotating and the flashing symbol -- appears on the display.	The product is equipped with a protection device that interrupts the operation of the motor in case of overload.	To reset it, turn off the appliance, unplug the product and let it cool for at least 10 minutes. Then reconnect the power supply to the socket.
The accessories do not fit into their seat.	The place of insertion of the accessory is not the correct one.	Respect the shape of the accessory by coupling it with its seat.



If the problem cannot be solved or for other types of faults, contact the local after-sales service.

The appliance complies with European directives 2014/35/EC, 2014/30/EC and 2009/125/EC.

The conformity according to EN60335 clause 11 was verified by using the following preparations:

- A. Wire beaters: 5 egg whites. Short Operation Time: 2 mins and 20 seconds. Speed: 9;
- B. Optimus beaters: 500 ml cream. Short Operation Time: 4 mins. Speed: 9;
- C. Dough hooks: 900g flour + 648g water. Short Operation Time: 5 mins. Speed:9.