

MANUALE D'USO

BOLLITORE

IT

INSTRUCTION MANUAL

KETTLE

EN

MANUEL D'UTILISATION

BOUILLLOIRE

FR

BEDIENUNGSHANDBUCH

WASSERKOCHER

DE

GEbruIKSAANWIJZING

WATERKOKER

NL

MANUAL DE USO

HERVIDOR

ES

MANUAL DE UTILIZAÇÃO

FERVEDOR

PT

BRUKSANVISNING

VATTENKOKARE

SV

РУКОВОДСТВО ПО ЭКСПЛУАТАЦИИ

ЭЛЕКТРИЧЕСКИЙ ЧАЙНИК

RU

BRUGERVEJLEDNING

KEDEL

DA

INSTRUKCJA OBSŁUGI

CZAJNIK ELEKTRYCZNY

PL

KÄYTTÖOPAS

VESIPANNU

FI

BRUKSANVISNING

VANNKOKER

NO

دليل التعليمات

غلاية

AR

 smeg

Informazioni importanti per l'utente, Important information for the user, Informations importantes pour l'utilisateur, Wichtige Informationen für den Benutzer, Belangrijke informatie voor de gebruiker, Información importante para el usuario, Informações importantes para o utilizador, Viktig information för användaren, Важная информация для пользователя, Vigtig information til brugeren, Ważne informacje dla użytkownika, Tärkeitä tietoja käyttäjälle, Viktig informasjon for brukere, معلومات هامة للمستخدم



Avvertenze / Recommendations / Avertissements / Hinweise / Waarschuwingen / Advertencias / Advertências / Varningar / Меры предосторожности / Advarsler / Ostrzeżenia / Varoituset / Advarsler / تحذيرات



Descrizione / Description / Description / Beschreibung / Beschrijving / Descripción / Descrição / Beskrivning / Описание / Beskrivelse / Opis / Kuvaus / Beksrivelse / الوصف



Uso / Use / Utilisation / Gebrauch / Gebruik / Uso / Utilização / Användning / Использование / Anvendelse / Użytkowanie / Käyttö / Bruk / الإستعمال



Pulizia e manutenzione / Cleaning and care / Nettoyage et entretien / Reinigung und Wartung / Reiniging en onderhoud / Limpieza y mantenimiento / Limpeza e manutenção / Rengöring och underhåll / Чистка и техническое обслуживание / Rengöring og vedligeholdelse / Czyszczenie i konserwacja / Puhdistus ja hoito / Rengjøring og vedlikehold / التنظيف والصيانة



Avvertenza di sicurezza / Safety instructions / Consignes de sécurité / Sicherheitshinweise / Veiligheidswaarschuwingen / Advertencia de seguridad / Advertências de segurança / Säkerhetsvarning / Предупреждение о безопасности / Sikkerhedsanvisninger / Ostrzeżenie dotyczące bezpieczeństwa / Turvallisuuteen liittyvät varoituset / Sikkerhetsadvarsler / تحذير للسلامة



Informazione / Information / Information / Information / Informatie / Información / Informação / Information / Информация / Information / Informacja / Tietoa / Informasjon / معلومات



Suggerimento / Advice / Conseil / Empfehlungen / Aanbeveling / Sugerencia / Sugestões / Råd / Рекомендация / Forslag / Porada / Neuvo / Forslag / اقتراحات



Scansiona il QR code per un accesso rapido al portale My Smeg Assistant

Scan the QR code for quick access to the My Smeg Assistant portal

Scannez le code QR pour un accès rapide au portail My SMEG Assistant

Für den schnellen Zugriff auf das Portal My Smeg Assistant scannen Sie einfach den QR-Code

Scan de QR-code voor de Handleiding voor Snelle Installatie en Onderhoud

Escanee el código QR para acceder rápidamente al portal My Smeg Assistant

Leia o Código QR para ter acesso rápido ao portal My Smeg Assistant

Skanna QR-koden för att snabbt öppna portalen My Smeg Assistant

Отсканируйте QR-код для быстрого доступа к portalу My Smeg Assistant

Scan QR-koden for hurtigt at få adgang til portalen My Smeg Assistant

Zeskanuj kod QR, aby uzyskać szybki dostęp do portalu My Smeg Assistant

Skannaa QR-koodi, jonka avulla pääset nopeasti My Smeg Assistant -portaaliin

Skann QR-koden for hurtig tilgang til portalen My Smeg Assistant

امسح رمز الاستجابة السريعة من أجل الوصول سريعاً إلى بوابة My Smeg Assistant

Gentile Cliente, La ringraziamo vivamente per il Suo acquisto. I nostri prodotti sono unici perché uniscono una spiccata ricerca estetica alla progettazione tecnica innovativa. Essi sono coordinati con altri prodotti in gamma e possono costituire elementi d'arredo e di design. Augurandole di apprezzare appieno le funzionalità del Suo elettrodomestico, Le porgiamo i nostri più cordiali saluti.

Dear Customer, Thank you for purchasing one of our appliances. Our products are unique because they combine iconic style with innovative technical solutions. They match perfectly with other products in our range and work equally well as a standalone design objects in your kitchen. We hope you enjoy using your new appliance! Best regards.

Cher client, merci beaucoup pour votre achat. Nos produits sont uniques car ils combinent une forte recherche esthétique avec une conception technique innovante. Ils sont coordonnés avec d'autres produits de la gamme et peuvent constituer des éléments d'ameublement et de design. En espérant que vous pourrez apprécier pleinement votre nouvel appareil électroménager, nous vous adressons nos meilleures salutations.

Sehr geehrter Kunde, wir danken Ihnen herzlich für den Kauf. Unsere Produkte sind einzigartig, da sich in ihnen eine gewissenhafte Designforschung und eine innovative technische Planung vereinen. Sie sind mit anderen Produkten des Sortiments kombinierbar und stellen ausgefallene Einrichtungs- und Designgegenstände dar. Wir hoffen, dass Sie Ihr neues Haushaltsgerät voll und ganz schätzen werden und verbleiben mit freundlichen Grüßen.

Beste klant, hartelijk dank voor uw aankoop. Onze producten zijn uniek omdat ze esthetiek combineren met innovatief technisch ontwerp. De producten zijn uitstekend te combineren andere producten van het assortiment en kunnen worden gebruikt als meubel- en designelementen. We hopen dat u volop van uw nieuwe huishoudelijke apparaat zult genieten. Met vriendelijke groet

Estimado cliente, le damos las gracias por su compra. Nuestros productos son únicos porque combinan una notable búsqueda estética con un diseño técnico innovador. Se combinan con otros productos de la gama y se pueden utilizar como elementos de decoración y diseño. Le deseamos que pueda apreciar plenamente su nuevo electrodoméstico. Le enviamos nuestros saludos más cordiales.

Prezado cliente, Muito obrigado pela sua compra. Os nossos produtos são únicos porque combinam uma forte busca estética com um desenho técnico inovador. São coordenadas com outros produtos da linha e podem constituir elementos de decoração e design. Esperando que possa desfrutar totalmente das funcionalidades do seu eletrodoméstico, enviamos-lhe os nossos melhores cumprimentos.

Bäste kund, vi vill tacka dig för ditt köp. Våra produkter är unika eftersom de kombinerar ett estetiskt nytänkande med innovativ teknik. Våra produkter passar med de andra i samma serie och kan användas som föremål inom heminredningen för att ge en särskild känsla av stil i ditt hem. Vi hoppas att du till fullo kommer att uppskatta funktionerna hos din hushållsmaskin. Med bästa hälsningar.

Уважаемый покупатель! Благодарим Вас за покупку. Наши изделия уникальны, поскольку они сочетают в себе великолепный дизайн и передовые технические решения. Кроме того, они комбинируются с другими изделиями из этой линейки и могут стать стильными элементами интерьера и дизайна. Надеемся, что Вы в полной мере оцените функциональные возможности Вашего бытового прибора. С наилучшими пожеланиями.

Kære Kunde, mange tak for dit køb. Vores produkter er unikke, da de forener æstetisk research og innovativt teknisk design. De passer perfekt sammen med de andre produkter i serien, og kan stå som et enkeltstående møbel af design. Vi håber, at du vil værdsætte din hårde hvidevares funktionalitet, og sender de bedste hilsner.

Szanowny Kliencie, Dziękujemy za Twój zakup. Nasze produkty są wyjątkowe, ponieważ łączą intensywne badania estetyczne z innowacyjnym projektem technicznym. Są one skoordynowane z innymi produktami z asortymentu i mogą stanowić elementy wyposażenia i wystroju. Mamy nadzieję, że będą Państwo mogli w pełni korzystać z funkcjonalności tego urządzenia. Serdecznie pozdrawiamy.

Arvoisa Asiakas, kiitämme sinua hankintasi johdosta. Tuotteemme ovat ainutlaatuisia, koska niissä yhdistyvät esteettisyys ja innovatiivinen tekninen suunnittelu. Ne sopivat yhteen muiden valikoimaan kuuluvien tuotteiden kanssa toimien samalla sisustus- ja design-tuotteina. Toivomme, että voit nauttia täysin siemauksin kodinkoneesi toiminnoista. Sydämellisin terveisin.

Kjære kunde. Vi takker for at dere valgte å kjøpe et av våre produkter. Våre produkter er unike fordi de forener søken etter estetikk med en nyskapende teknisk design. De koordineres med andre produkter i vårt sortiment og kan ha funksjon som både møbel- og designvare. Vi håper du får fullt utbytte av ditt husholdningsapparat, og sender deg våre beste hilsener.

تحتفظ جهة التصنيع بحقها في إجراء أية تغييرات تراها ضرورية لتحسين منتجاتها دون إخطار مسبق. لذا، تعتبر الرسوم التوضيحية والأوصاف الواردة في هذا الدليل غير ملزمة ولكنها إرشادية فقط.

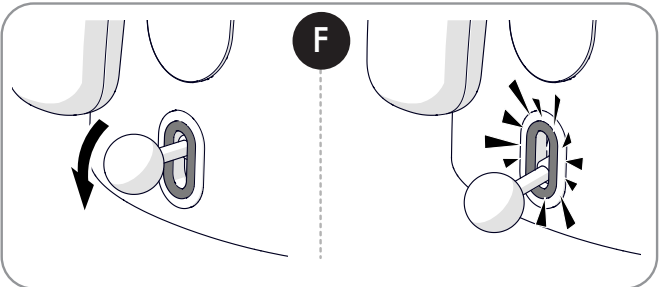
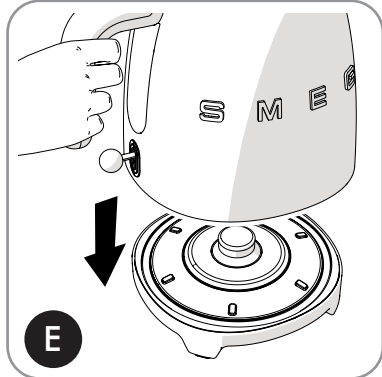
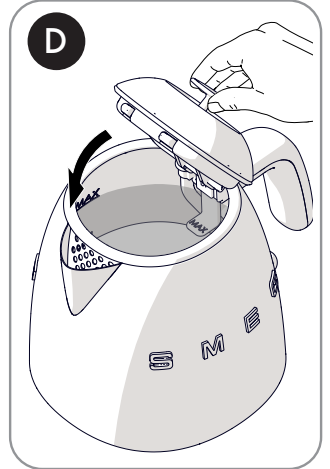
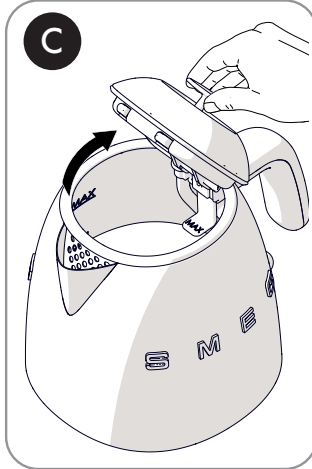
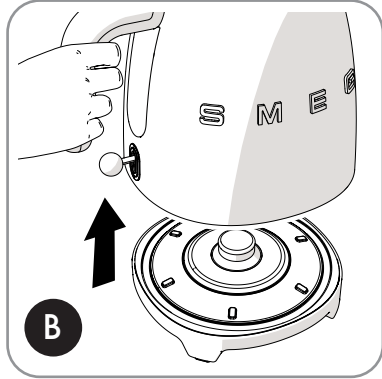
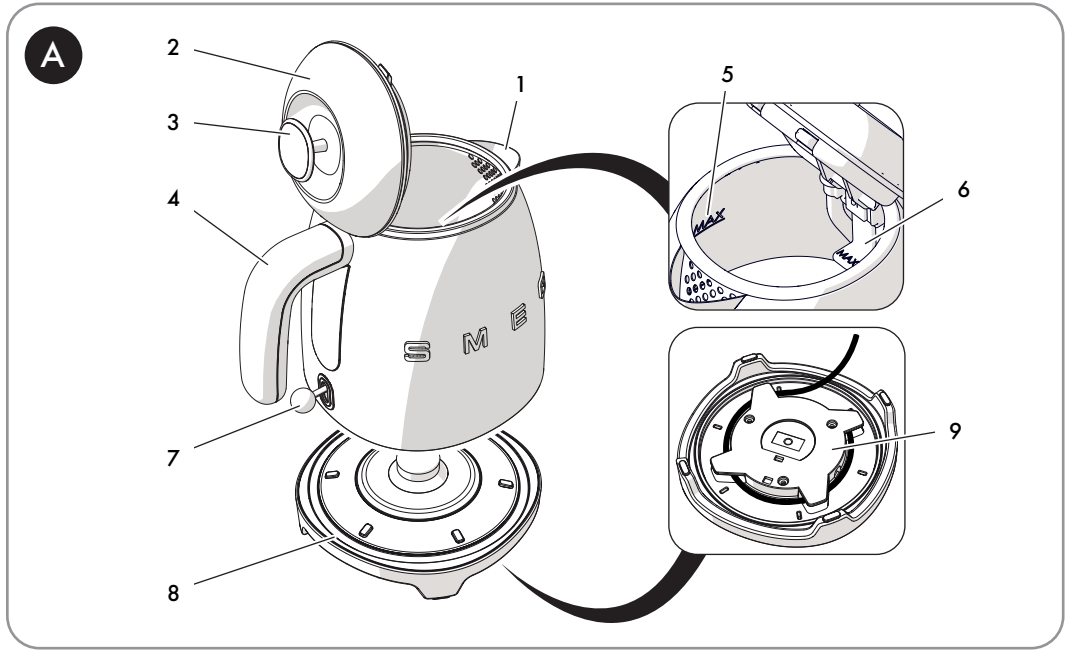



1 Instructions

This user manual is an integral part of the appliance and must therefore be kept in its entirety and within the user's reach for the whole working life of the appliance.

1.1 Intended use

- Only use the appliance indoors and at a maximum altitude of 2000 metres.
- This appliance is intended for household use and similar applications such as:
 - staff kitchen areas in shops, offices and other working environments
 - bed and breakfast facilities / farm accommodation
 - by guests in hotels, motels and other residential accommodations
- Any other use, for example in restaurants, coffee bars and coffee shops is considered improper.
- Only use the appliance to heat water. Never fill the kettle with other liquids.
- This appliance may be used by people of reduced physical, sensory or mental abilities (including children over the age of 8), only if they are supervised by adults or have been trained on how to use the appliance safely and have understood the dangers associated with its use.
- Children must never play with the appliance.
- Keep the appliance out of the reach of children younger than 8.
- Cleaning and maintenance may be carried out by children who are at least 8 years old only if they are supervised by an adult.

1.2 General safety instructions

- Do not immerse the appliance, the power cord, the plug or the base in water or any other liquid. Do not unplug the appliance with wet hands, or by pulling on the power cord.
- Never wash the appliance in the dishwasher.
- Do not position the appliance above hot surfaces, hob burners, or inside a hot oven.
- In the event of a fault, or if the power cable is damaged, the appliance must be repaired only by a qualified technician or an authorised technical support centre.
- Any modifications to the appliance will make the warranty invalid.

1.3 Caution

- Do not use the kettle if the handle is loose.
- Make sure that the inside bottom of the kettle is completely covered with water before switching it on.
- Only use the kettle with the base provided.
- Make sure that the lid is correctly closed before switching on the kettle.
- Only use original spare parts. The use of spare parts not approved by the manufacturer could lead to fires, electric shocks or personal injury.



Instructions

1.4 Manufacturer liability

The manufacturer declines any liability for damage to persons or property caused by:

- Use of the appliance other than the one envisaged
- Not having read the user manual
- Tampering with any part of the appliance
- Use of non-original spare parts
- Failure to comply with the safety instructions

1.5 Disposal



This appliance must be disposed of separately from other waste (Directive 2012/19/EU).

- The appliance does not contain substances in quantities sufficient to be considered hazardous to health and the environment, in accordance with current European directives.
- Old electrical appliances must not be disposed of together with household waste! To comply with current legislation, old appliances, on reaching the end of their useful lives, should be taken to a disposal facility where they can be sorted. The relevant local authorities or their waste disposal operators can provide further information.
- Take these packing materials to the appropriate recycling centre.



Fire hazard:

- Do not position the appliance above hot surfaces, hob burners, or inside a hot oven.



Danger of burns:

- Do not overfill the kettle (maximum capacity 0.8 litres indicated by the red maximum level indicator) to prevent boiling water from being splashed out.
- The surfaces of the kettle may become very hot. Avoid touching hot surfaces; use the handle.
- Wait a few seconds after the kettle has reached boiling temperature, then pour the water out slowly to prevent hot water from spraying or coming out too fast.
- Do not tilt the hot kettle excessively – the boiling water could spray out, with a risk of burns.
- Keep your face at safe distance from the lid to avoid the risk of burns from escaping steam.
- Let the appliance cool down before cleaning.
- Pay attention: The heating element surface is subject to residual heat after use.

Instructions



Suffocation hazard due to plastic packaging:

- Do not leave the packaging or any part of it unattended.
- Do not let children play with the plastic bags.



Caution

- To clean surfaces that come into contact with food, follow the special cleaning procedures provided in the instructions.



Risk of injury:

- Improper use of the appliance can cause injury.



Danger of electrocution:

- Plug into an grounded 3-prong outlet.
- Do not remove the earth prong.
- Do not use an adapter.
- Do not use an extension cord.
- Avoid spilling liquids onto the power plug and base.
- Unplug the kettle when it is not being used, before cleaning and if you notice any fault.
- Failure to follow these instructions could result in death, fire, or electrical shock.



Do not use the appliance near baths, showers, sinks or other water containers.



2 Product description (Fig. A)

- 1) Anti-drip spout
- 2) Lid with manual opening
- 3) Knob
- 4) Handle
- 5) Graphic minimum and maximum water level indicator
- 6) Internal maximum water level indicator
- 7) ON/OFF lever with indicator light
- 8) Anti-slip base with 360° swivel base.
- 9) Cord wrap (under base)



To avoid damaging the appliance, the kettle is equipped with a safety device that automatically turns the lever to the OFF position if the kettle is accidentally switched on without water.

If this occurs, let the kettle cool down before starting the boiling cycle again.

3 Use

3.1 Before first use

- 1) Remove all stickers and labels from the kettle and clean the outside with a damp cloth.
- 2) Remove the kettle from its base (Fig. B), use the knob to open the lid (Fig. C) and fill it to the maximum level, indicated by the indicators inside the kettle (5 and 6 - Fig. A).
- 3) Close the lid (Fig. D), place the kettle on its base (Fig. E) and push the lever down to turn it on (Fig. F).
- 4) Wait for the water to boil, then empty the kettle, disposing of the boiling water safely. Repeat this operation at least three times.

3.2 Operation

If necessary, wrap the cable under the base (8 and 9 - Fig. A).

Always use the handle (4 - Fig. A) to lift the kettle and pour out the water.

- 1) To begin, remove the kettle from the base (Fig. B), use the knob to open the lid (Fig. C) and fill with water, using the maximum level indicators as reference (5 and 6 - Fig. A). Avoid adding too much or too little water, indicated by the minimum level indicator.
- 2) Close the lid (Fig. D) and place the kettle back on its base (Fig. E).
- 3) Then place the plug into the power socket.
- 4) Push the lever downwards to turn the kettle on. The LED lights up and becomes white (Fig. F).
- 5) When the water boils, the lever automatically moves into the OFF position and the LED switches off. Pour out the water.



4 Cleaning and maintenance

4.1 Cleaning the surfaces

To keep the outside surfaces of the kettle in good condition, clean them regularly after each use after allowing them to cool down. Pour the product onto a damp cloth and clean the surface, wipe thoroughly once more and then dry with a soft cloth or a microfibre cloth.

Improper use: Risk of damage to surfaces

- Do not use steam jets to clean the appliance.
- Do not use cleaning products containing chlorine, ammonia or bleach.
- Do not use abrasive or corrosive detergents (e.g. powder products, stain removers and metallic scourers).
- Do not use rough or abrasive materials or sharp metal scrapers.

4.2 Descaling

Improper use: Risk of damaging the appliance



Do not use descaling products for cleaning bathrooms or kitchens or products that contain perfumes.

Regularly removing scale deposits from inside the kettle will prolong your kettle's life, ensuring maximum performance and energy savings.

The kettle can be descaled using specific descaling products. Follow the descaler instructions.

Alternatively, you can use common household vinegar.

Proceed as follows:

- 1) Fill the kettle with water (0.5-0.6 litres) and boil it.
- 2) Add white vinegar (0.1 to 0.2 l depending on the amount of scale).
- 3) Leave it to act overnight.
- 4) Empty the kettle.
- 5) Fill the kettle with water and boil it. Empty the kettle, disposing of the water safely. Repeat this operation at least twice.



Tips and suggestions for the user

Frequent use or very hard water increases the risk of scale.

Scale build-up can cause the kettle to switch off during use before the water has boiled.

Boiling times could also increase.

If the kettle is used daily, descale it more frequently. If the water is hard, clean more frequently or use purified water.

What to do if...

Problem	Cause	Solution
The kettle turns off before boiling	The base of the kettle has excessive scale build-up	Descale more frequently
	There is too little water in the kettle	Increase the quantity of water until you reach at least the minimum level
The appliance does not turn on	The safety device has tripped out due to the kettle being operated without water	Let the kettle cool down before attempting to boil water again
	The plug is not properly inserted in the power socket	Insert the plug into the power socket. Do not use adaptors or extensions. Make sure that the main circuit breaker is on
	The cable is defective	Have the cable replaced at an Authorised Service Centre
	Lack of power	Make sure that the main circuit breaker is on

Il costruttore si riserva di apportare senza preavviso tutte le modifiche che riterrà utili al miglioramento dei propri prodotti. Le illustrazioni e le descrizioni contenute in questo manuale non sono quindi impegnative ed hanno solo valore indicativo.

The manufacturer reserves the right to make any changes deemed necessary for the improvement of its products without prior notice. The illustrations and descriptions contained in this manual are therefore not binding and are merely indicative.

Le fabricant se réserve la faculté d'apporter, sans préavis, toutes les modifications qu'il jugera utiles pour l'amélioration de ses produits. Les illustrations et les descriptions figurant dans ce manuel ne sont pas contraignantes et n'ont qu'une valeur indicative.

Der Hersteller behält sich vor, ohne vorherige Benachrichtigung alle Änderungen vorzunehmen, die er zur Verbesserung seiner Produkte für nützlich erachtet. Die in diesem Handbuch enthaltenen Illustrationen und Beschreibungen sind daher unverbindlich und dienen nur zur Veranschaulichung.

De fabrikant behoudt zich het recht voor zonder waarschuwing alle wijzigingen aan te brengen die hij nodig acht om zijn producten te verbeteren. De afbeeldingen en de beschrijvingen die aanwezig zijn in deze handleiding zijn niet bindend, en hebben enkel een aanduidende waarde.

El fabricante se reserva el derecho a aportar sin aviso previo todas las modificaciones que considere útiles para la mejora de sus propios productos. Las ilustraciones y las descripciones contenidas en este manual no son vinculantes y tienen solo valor indicativo.

O fabricante reserva-se o direito de efetuar, sem aviso prévio, qualquer modificação que vise o melhoramento dos respetivos produtos. As ilustrações e descrições contidas neste manual não são, por isso, vinculativas e possuem apenas valor indicativo.

Tillverkaren förbehåller sig rätten att genomföra alla de ändringar som anses nödvändiga för att förbättra de egna produkterna utan att meddela detta i förväg. De illustrationer och beskrivningar som finns i aktuell manual är därmed inte bindande utan endast indikativa.

Для улучшения выпускаемой продукции изготовитель оставляет за собой право вносить без предварительного предупреждения любые изменения, которые он сочтет целесообразными. Рисунки и описания, содержащиеся в данном руководстве, не являются обязывающими и носят ознакомительный характер.

Fabrikanten forbeholder sig retten til, uden varsel, at udføre alle de ændringer, der vurderes nyttige for at forbedre egne produkter. Tegningerne og beskrivelserne i denne manual er derfor kun vejledende og ikke bindende.

Producent zastrzega sobie prawo do nanoszenia, bez uprzedniego powiadomienia, wszelkich zmian, które uzna za stosowne w celu ulepszenia swoich produktów. Rysunki i opisy zawarte w niniejszej instrukcji nie są zobowiązujące i mają jedynie charakter orientacyjny.

Valmistaja pidättää itsellään oikeuden tehdä ohjeisiin mielestään tarpeellisia muutoksia ilman ennakkoilmoitusta. Tässä oppaassa olevat kuvat ja piirrookset eivät näin ollen ole sitovia, vaan ne annetaan vain viitteellisessä mielessä.

Produzenten forbeholder seg rett til å foreta endringer på sine produkter grunnet tekniske fremskritt, uten forutgående varsel. Illustrasjonene og beskrivelsene i denne bruksanvisningen er derfor ikke bindende og skal kun betraktes som retningsgivende.

عملينا العزيز، شكرا لك على شراء أحد أجهزتنا. تعد منتجاتنا فريدة لأنها تجمع بين الأسلوب المميز والحلول التقنية المبتكرة. وهي تتناسب تماما مع المنتجات الأخرى في مجموعتنا وتعمل بنفس القدر كتصميمات قائمة بذاتها في مطبخك. نأمل أن تستمتع باستخدام هذا الجهاز الجديد! وتفضلوا بقبول وافر الاحترام والتقدير.